

PRE-ENGINEERED SYSTEMS OVERVIEW

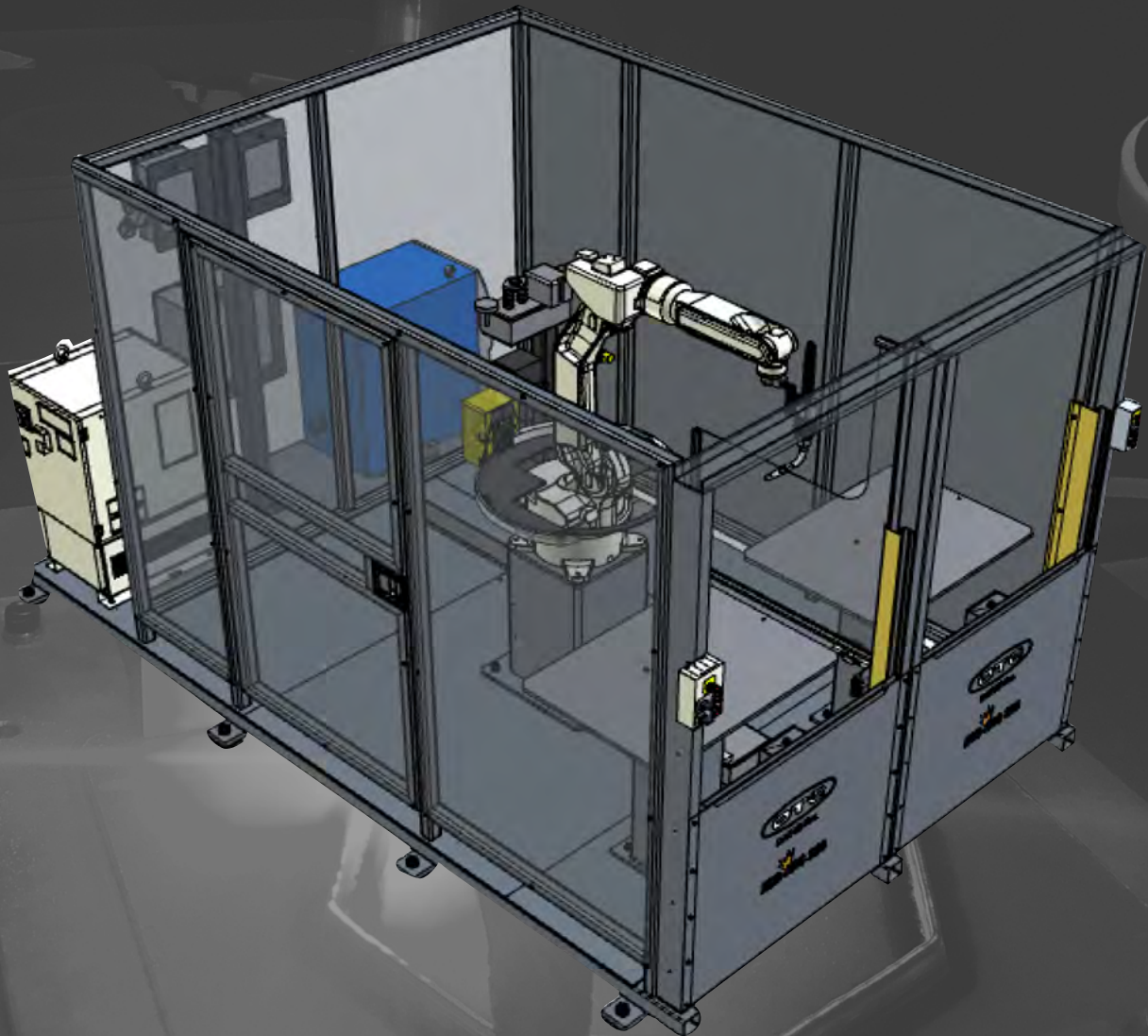

DAIHEN INC.

Contents

ED-ARC 100..... 1
ECO-ARC 200..... 3
ECO-ARC 200B 5
ECO-ARC 200L..... 7
ECO-ARC 200LB 9
ECO-ARC 290 11
ECO-ARC 290B 13
ECO-ARC mini..... 15
PT-ARC 600 17
PT-ARC 600B..... 19
SERVO-ARC 600 21
SERVO-ARC 600B..... 23
SERVO-ARC 720 25
SERVO-ARC 720B..... 27
DT-ARC 500 29
ROTA-ARC 250..... 31
ROTA-ARC 500..... 33
ROTA-ARC 1000..... 35
TRI-ARC 1000 37



DAIHEN INC.

ED-ARC 100

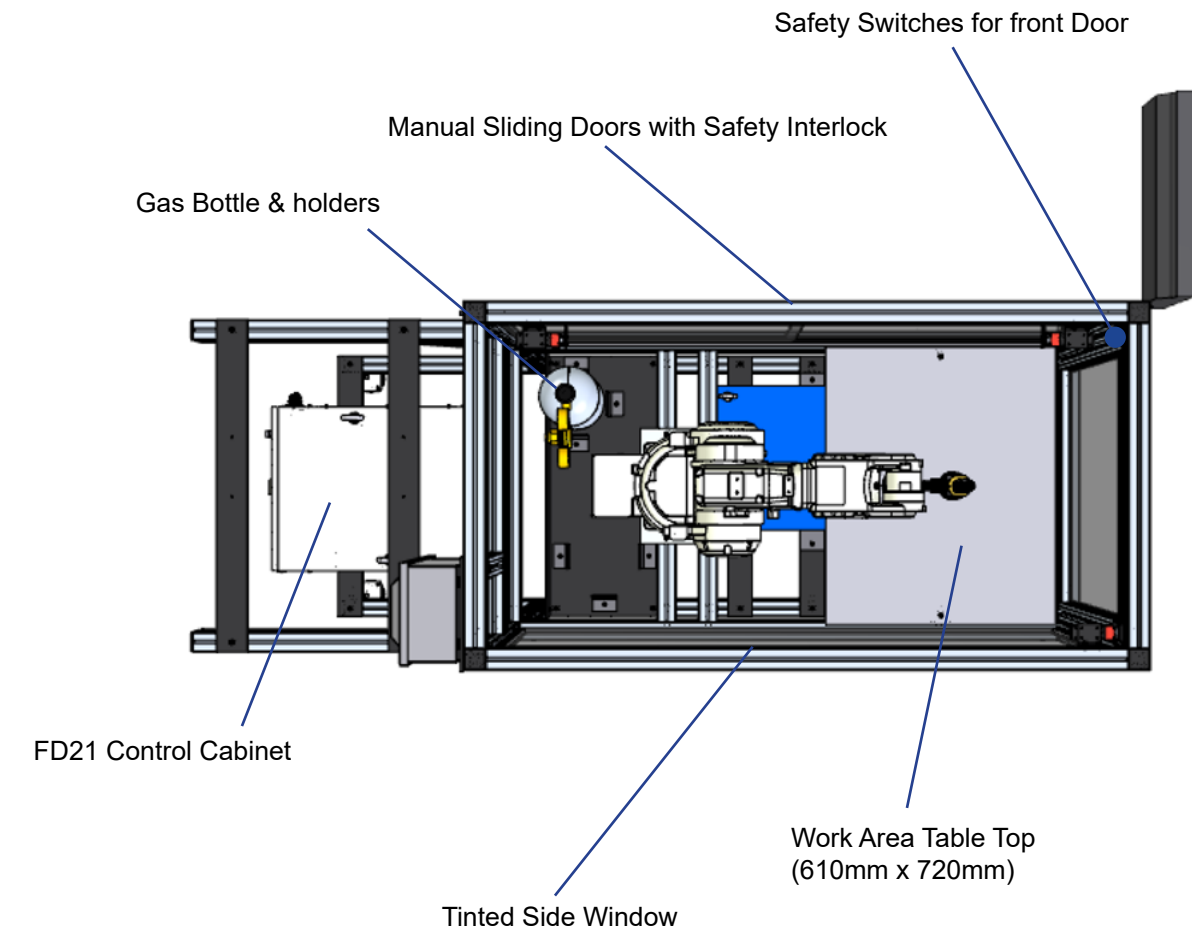
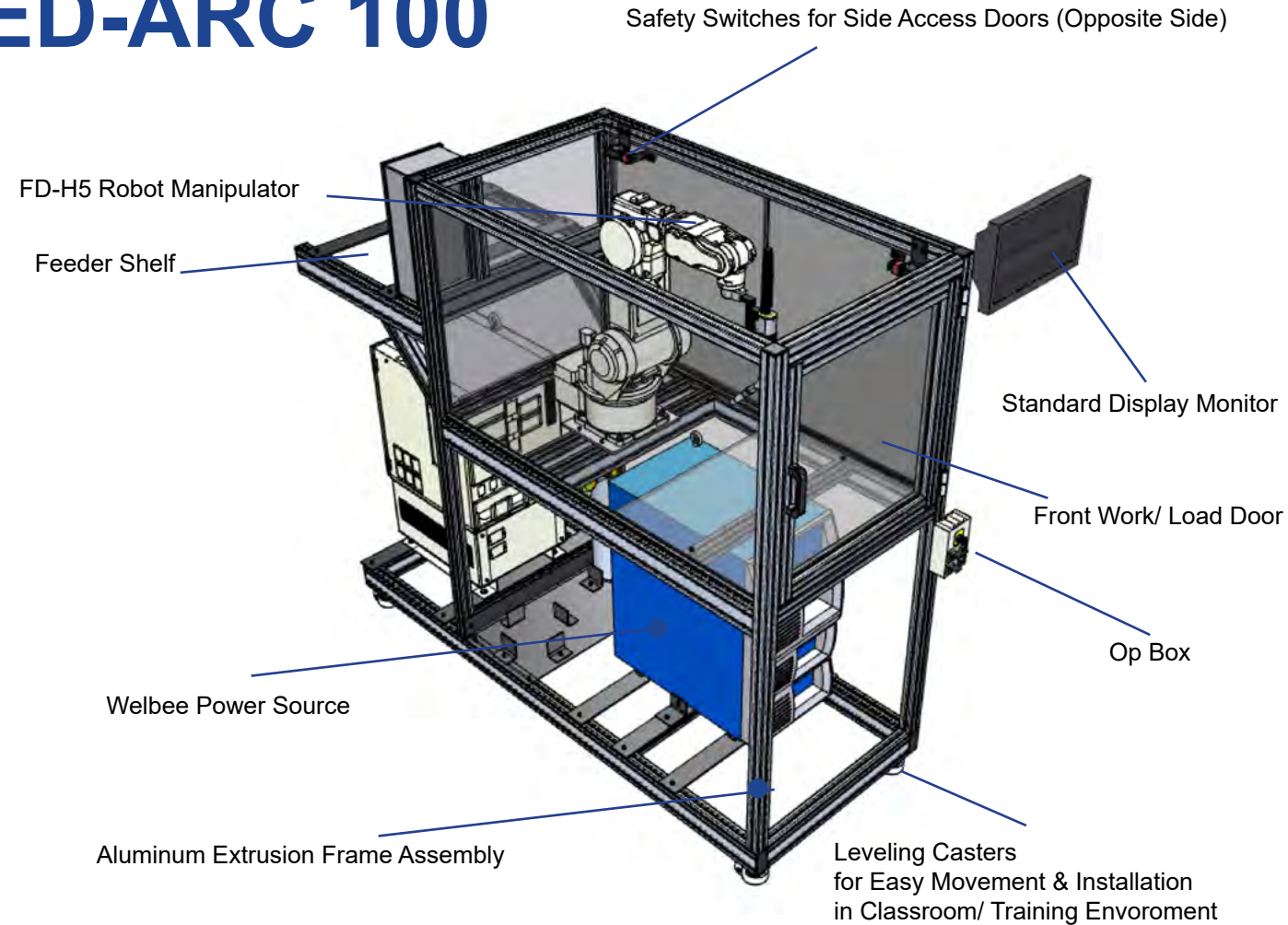

Standard Configuration:

ED-ARC 100

Mobile, fully enclosed arc welding training station with compact robot manipulator FD-H5

Details:

- Lightweight aluminum frame and polycarbonate arc flash enclosure
- Flat table top surface with 610mm x 720mm work area
- Height of work area 1177mm
- Maximum payload: 250kg
- Leveling casters for stable installation/easy movement when needed
- Weight: Approx. 550kg
- Front load access door with tinted window and safety interlock
- Side access door with tinted window for load/maintenance and safety interlock
- Tinted panels provide better light in work area for training visibility and operator safety
- Shelf mounted welding power source
- Standard Display Monitor



FD-H5

Specifications:

Footprint Dimensions:

Width: 820mm (32.3")
 Height: 2014mm (79.3")
 Depth: 2320 (91.3")

Manipulator Types:

- FD-H5

Available I/O Slots:

32 Inputs/32 Outputs
 (Additional Power Supply needed for Outputs)

Other Options:

- Optional Additional Work Area
 - Adds additional space by adding to the extruded frame and removing the long side panel without sliding doors
 - May require adding a zone kit for station designation

ECO-ARC 200

FD21 Control Cabinet

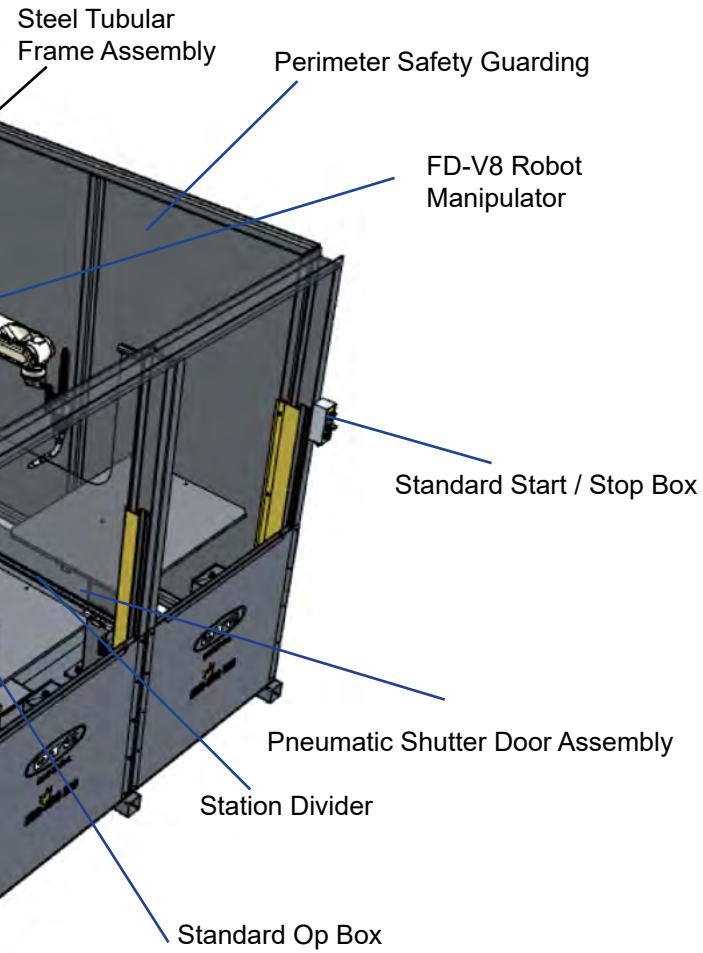

Common Base Platform (Full Plate) W/Trailer

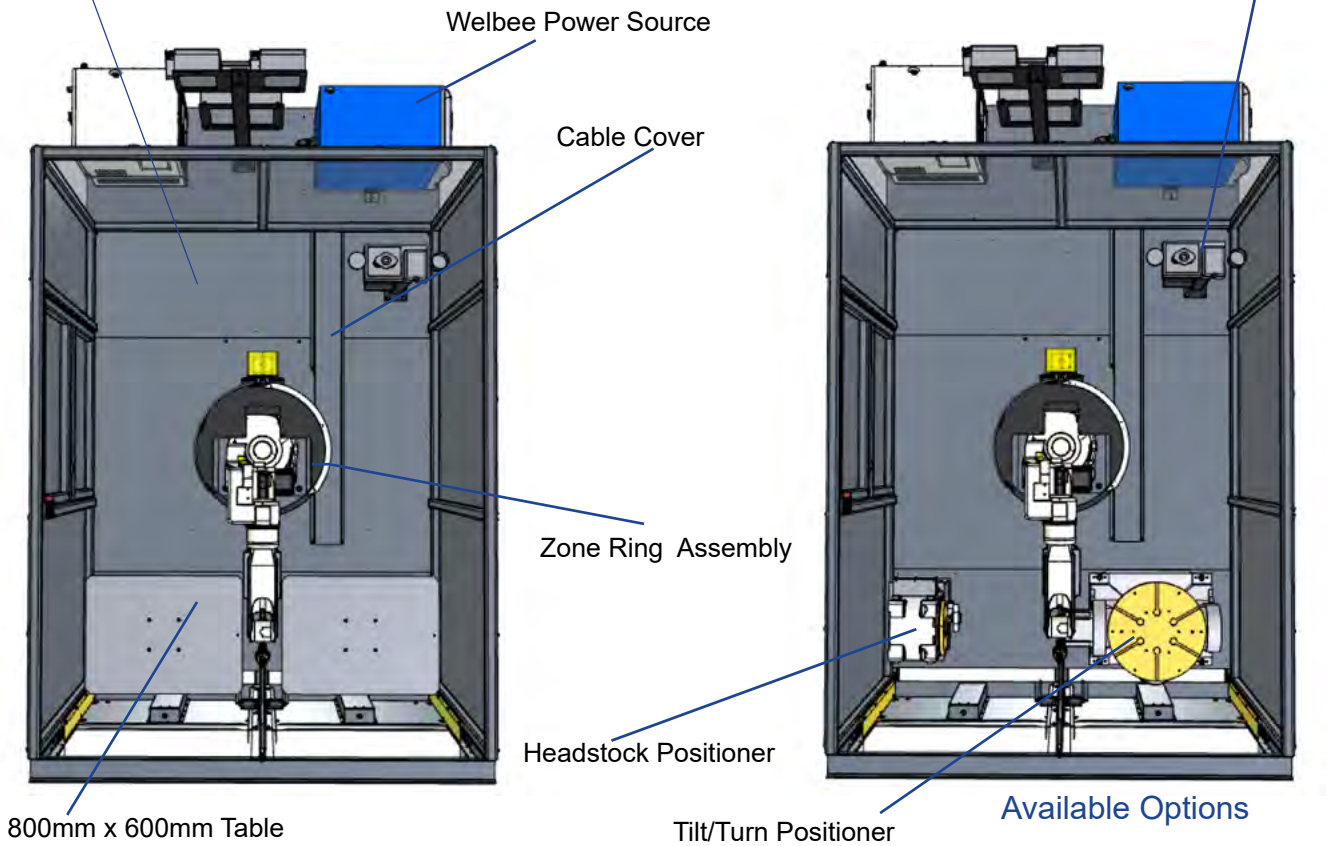

Standard Configuration:

ECO-ARC 200

2 stationary tables with standard robot manipulator (FD-V8)

Details

- Pneumatic shutter doors
- Zone Ring for station designation
- Standard fork lift pockets in base for easy movement
- Steel wall station divider
- Tabletop Dimensions: 800mm x 600mm
- Weight: Approx. 2000kg

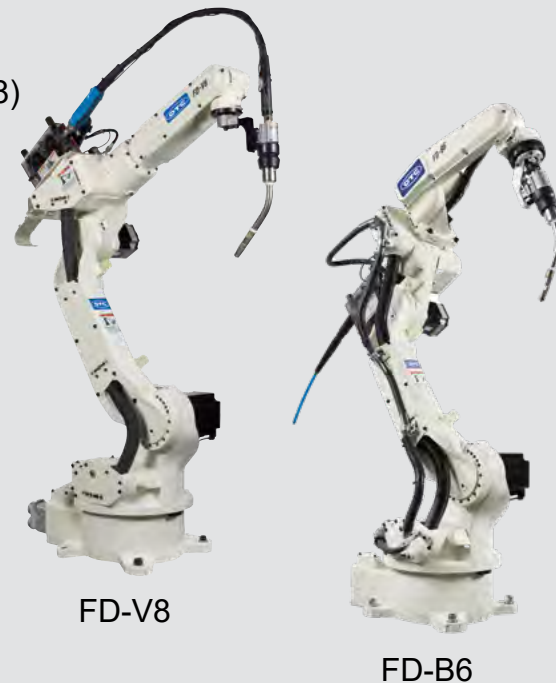

Specifications:

Footprint Dimensions:
 Width: 2194mm (86.4")
 Height: 2158mm (85.0")
 Depth: 3430mm (135.0")

Manipulator Types:

- FD-V8
- FD-B6

Cell Options:

- 2 Stationary tables
- Positioner/Table
- 2 Positioners

Headstock Options:

- A2PB-250
- A2PB-500
- A2PB-1000

Tilt/Turn Options:

- A2PF-300
- A2PF-500
- A2PF-1000

Available I/O Slots:

28 Inputs/26 Outputs
 (Additional Power Supply needed for Outputs)

Other Options:

- Basic Base Design (ECO-ARC 200B)
- Safety Fencing on Floor
- Safety Fencing on Full Base
- Access Door on RH Side
- Manual Sliding Door Assembly
- Station Lighting
- Torch Cleaning Station
- Fixture Mounting Pattern in Table Top
- Extended I/O

ECO-ARC 200B

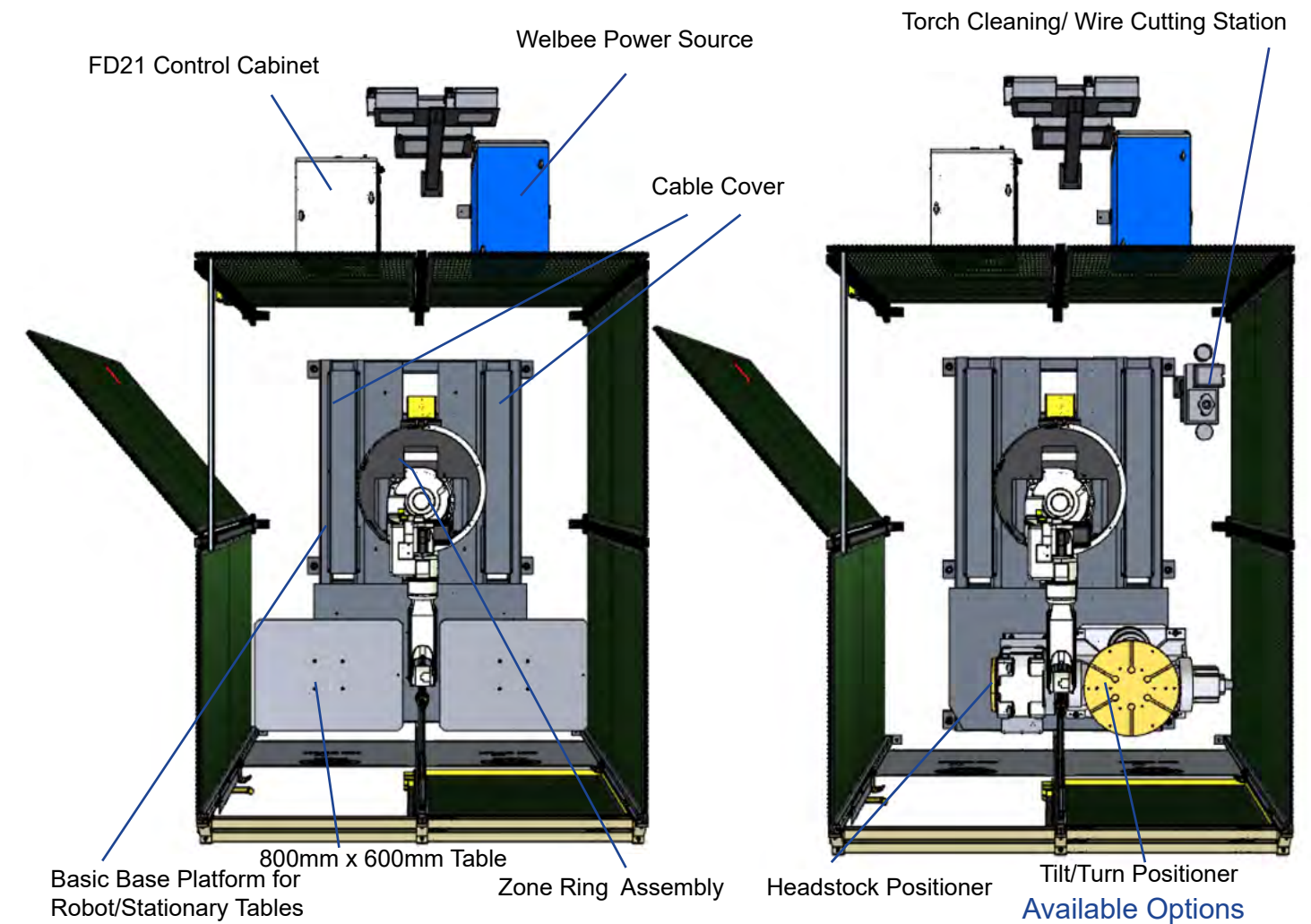
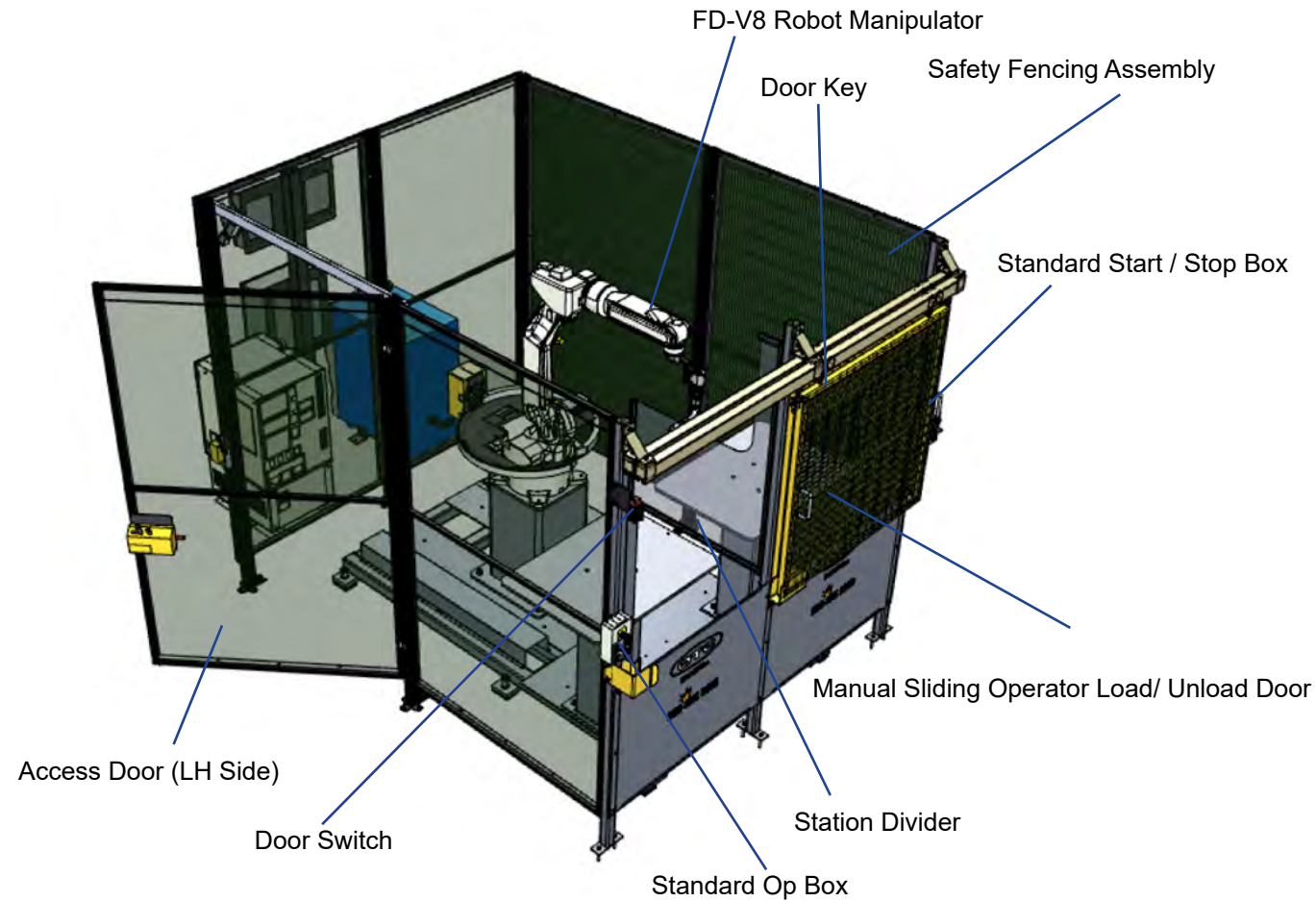

Standard Configuration:

ECO-ARC 200B

2 stationary tables with standard robot manipulator (FD-V8)

Details:

- Manual sliding operator load doors
- Zone Ring for station designation
- Standard fork lift pockets in base for easy movement
- Steel wall station divider
- Tabletop Dimensions: 800mm x 600mm
- Weight: Approx. 1500kg
- Floor mounted safety fencing w/ arc flash curtains



Specifications:

Footprint Dimensions:

Width: 2140mm (84.2")
 Height: 2200mm (86.6")
 Depth: 3575mm (140.7")

Manipulator Types:

- FD-V8
- FD-B6

Cell Options:

- 2 Stationary tables
- Positioner/Table
- 2 Positioners

Headstock Options:

- A2PB-250
- A2PB-500
- A2PB-1000

Tilt/Turn Options:

- A2PF-300
- A2PF-500
- A2PF-1000

Available I/O Slots:

28 Inputs/26 Outputs
 (Additional Power Supply needed for Outputs)

Other Options:

- Full Base Design (ECO-ARC 200)
- Mesh Fencing on Full Base
- Access Door on RH Side
- Pneumatic Shutter Door Assembly
- Station Lighting
- Torch Cleaning Station
- Fixture Mounting Pattern in Table Top
- Extended I/O
- Trailer (Base)

ECO-ARC 200L

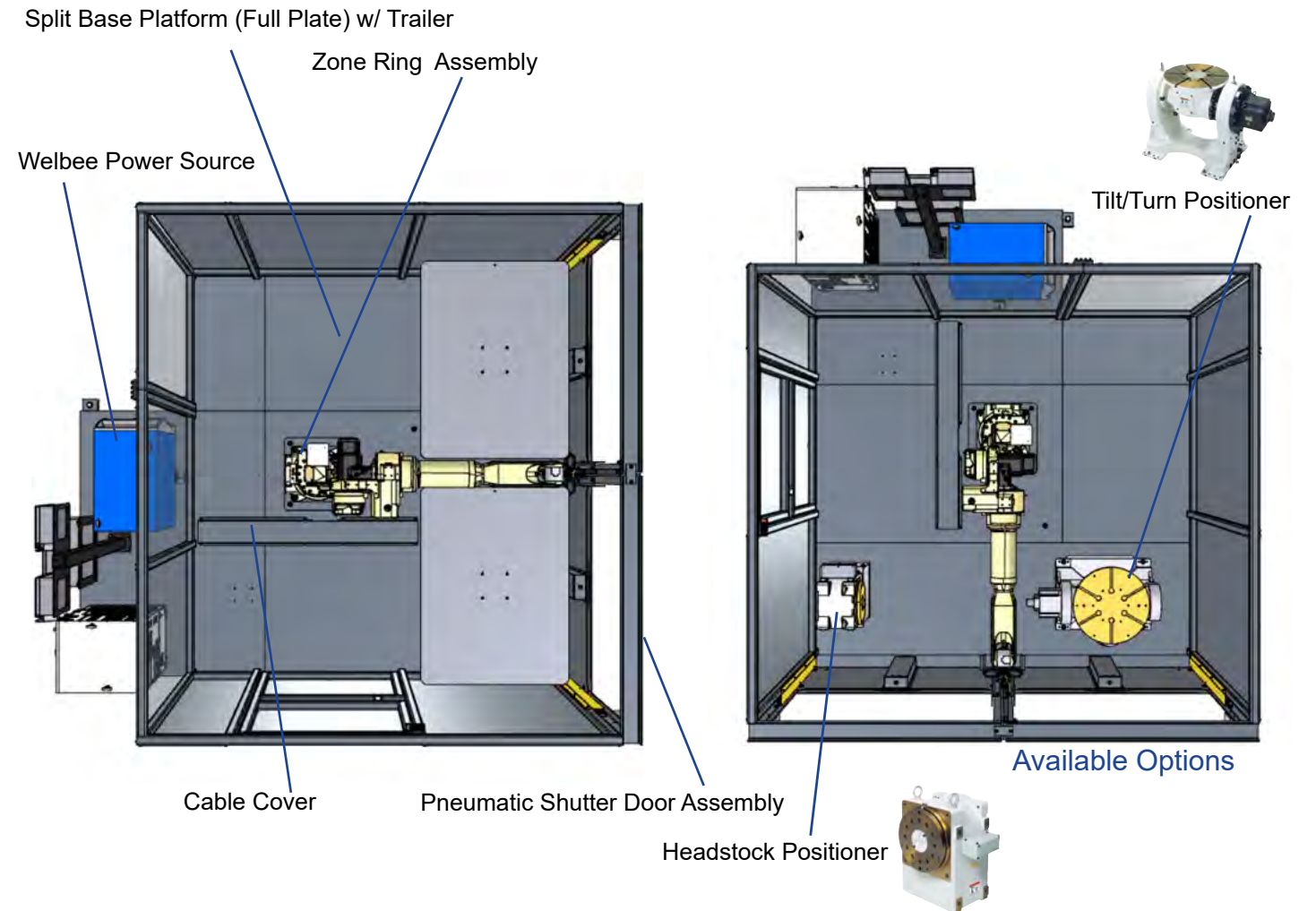
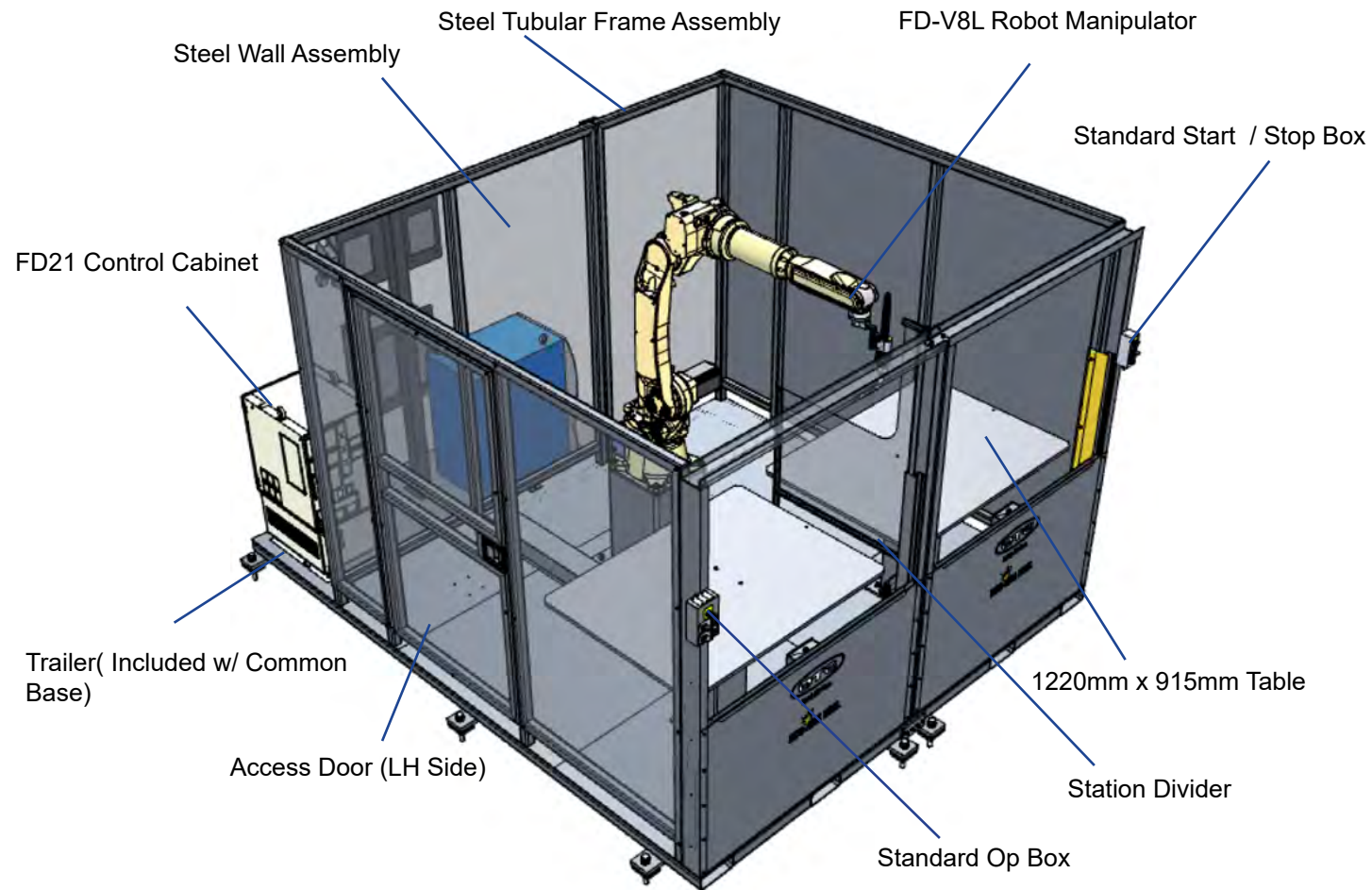

Standard Configuration:

ECO-ARC 200L

2 stationary tables with long reach robot manipulator FD-V8L(S2)

Details

- Pneumatic shutter doors
- Zone Ring for station designation
- Standard fork lift pockets in split base for easy movement
- Steel wall station divider
- Table Top Dimensions: 1220mm x 915mm
- Weight: Approx. 3500kg



Specifications:

Footprint Dimensions:
 Width: 2960mm (116.5")
 Height: 2200mm (86.6")
 Depth: 3440mm (135.4")

Manipulator Types:

- FD-V8L-S2
- FD-B6L-S2

Cell Options:

- 2 Stationary tables
- Positioner/Table
- 2 Positioners

Headstock Options:

- A2PB-250
- A2PB-500
- A2PB-1000

Tilt/Turn Options:

- A2PF-300
- A2PF-500
- A2PF-1000

Available I/O Slots:

28 Inputs/26 Outputs
 (Additional Power Supply needed for Outputs)

Other Options:

- Basic Base Design (ECO-ARC 200LB)
- Safety Fencing on Floor
- Safety Fencing on Full Base
- Access Door on RH Side
- Manual Sliding Door Assembly
- Station Lighting
- Torch Cleaning Station
- Fixture Mounting Pattern in Table Top
- Extended I/O

ECO-ARC 200LB

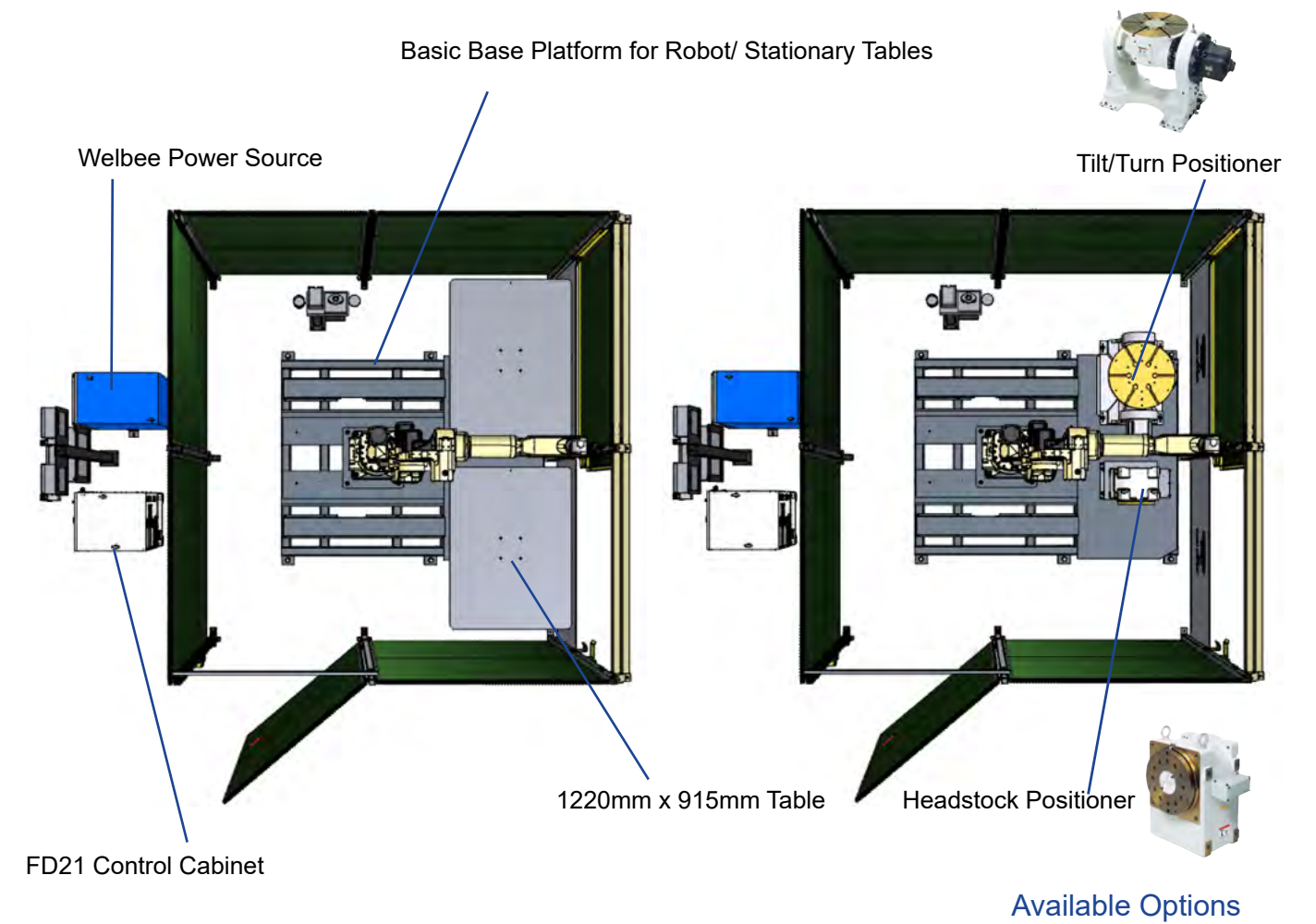
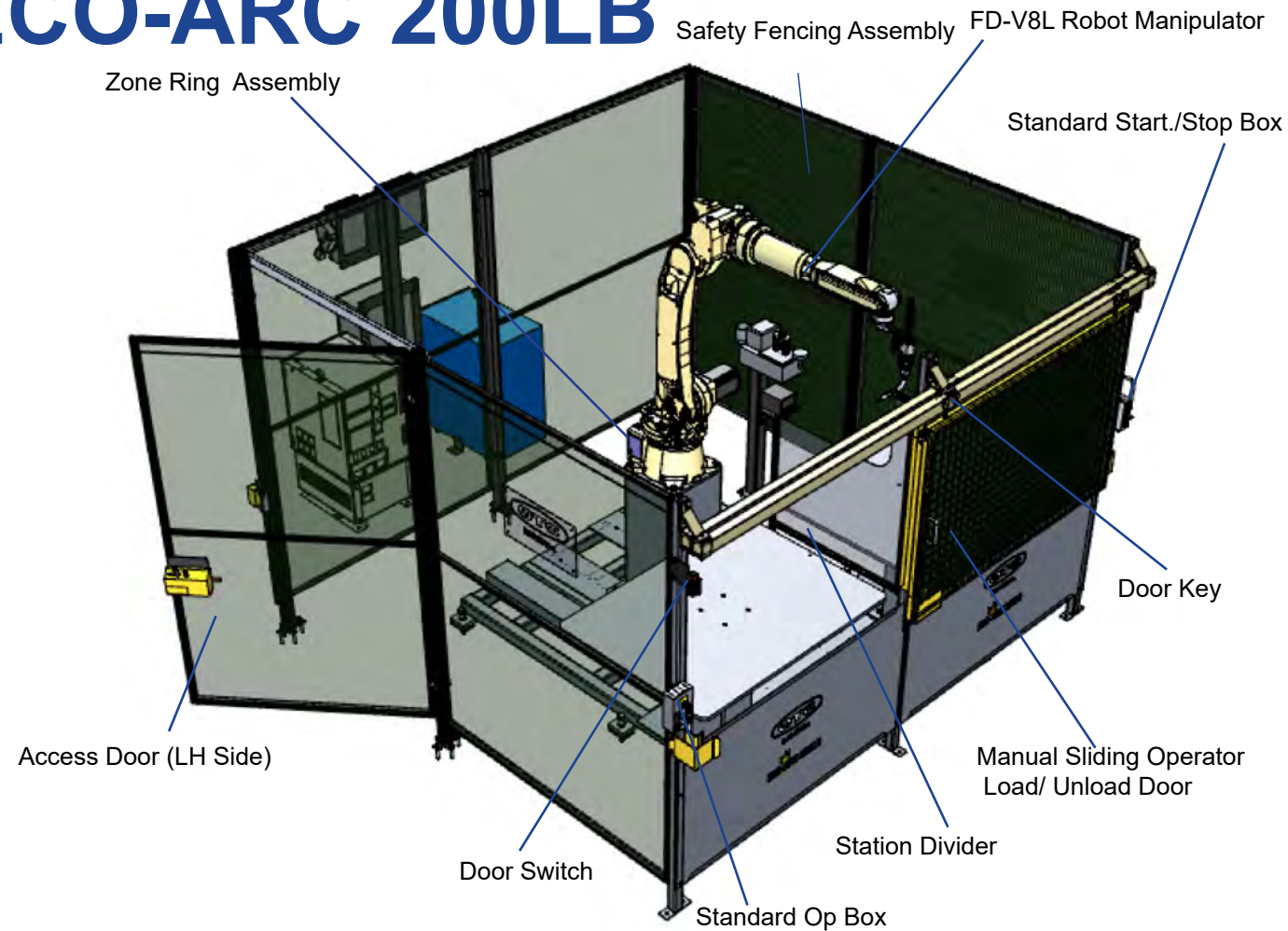

Standard Configuration:

ECO-ARC 200LB

2 stationary tables
with long reach robot manipulator FD-V8L-S2

Details:

- Manual sliding operator load doors
- Zone Ring for station designation
- Standard fork lift pockets in base for easy movement
- Steel wall station divider
- Tabletop Dimensions: 1220mm x 915mm
- Weight: Approx. 2000kg
- Floor mounted safety fencing w/ arc flash curtains

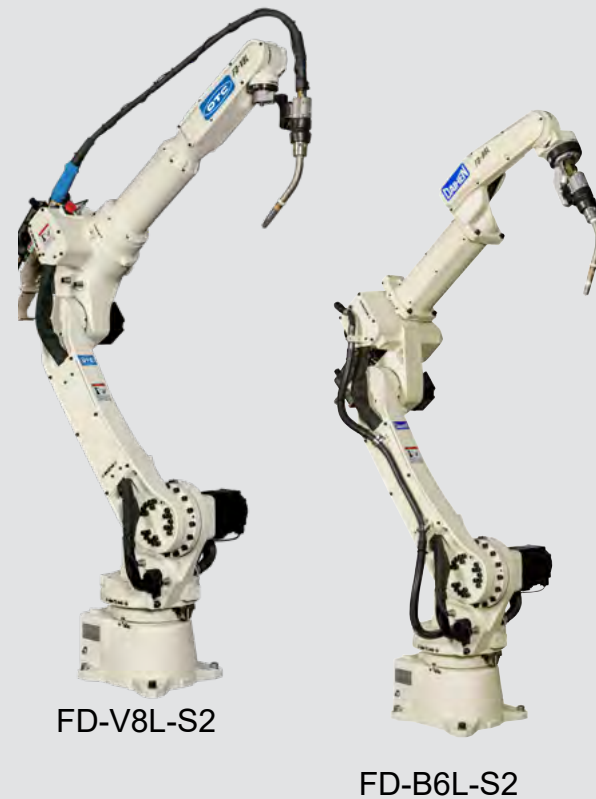

Specifications:

Footprint Dimensions:
Width: 3294mm (129.7")
Height: 2200mm (86.6")
Depth: 3915mm (154.1")

Manipulator Types:

- FD-V8L-S2
- FD-B6L-S2

Cell Options:

- 2 Stationary tables
- Positioner/Table
- 2 Positioners

Headstock Options:

- A2PB-250
- A2PB-500
- A2PB-1000

Tilt/Turn Options:

- A2PF-300
- A2PF-500
- A2PF-1000

Available I/O Slots:

28 Inputs/26 Outputs
(Additional Power Supply needed for Outputs)

Other Options:

- Full Base & Wall Design (ECO-ARC 200L)
- Mesh Fencing on Full Base
- Access Door on RH Side
- Pneumatic Shutter Door Assembly
- Station Lighting
- Torch Cleaning Station
- Fixture Mounting Pattern in Table Top
- Extended I/O
- Trailer (Base)

ECO-ARC 290

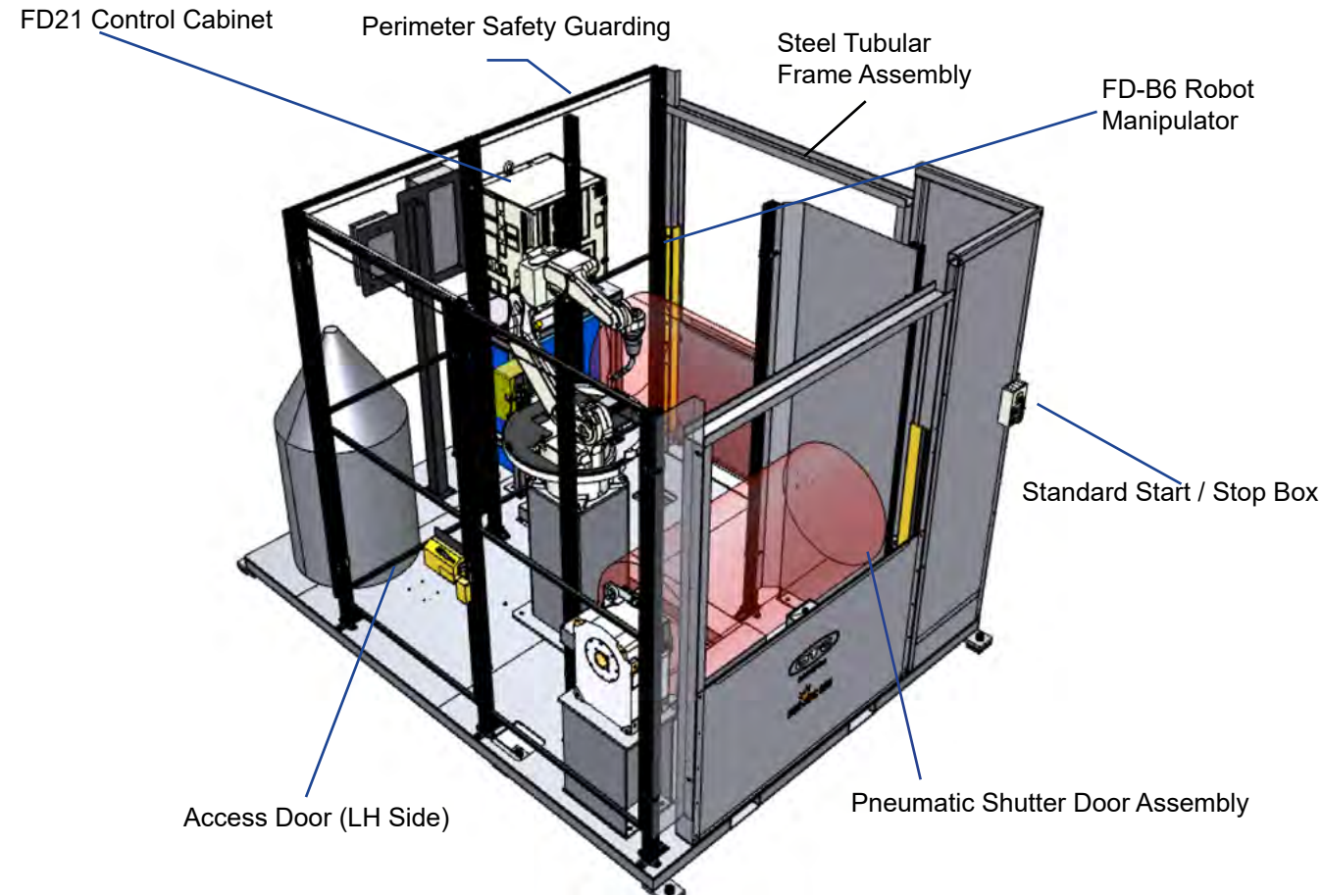

Common Base Platform (Full Plate) W/Trailer

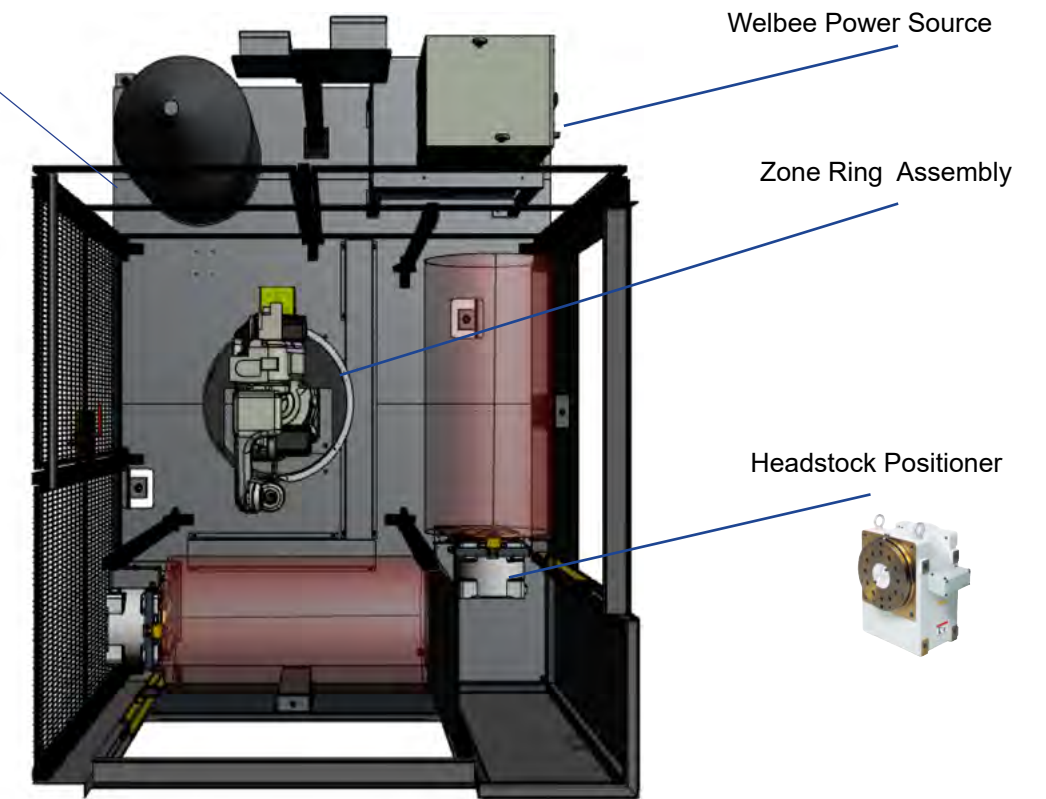

Standard Configuration:

ECO-ARC 290

2 Servo-controlled headstocks with standard robot manipulator (FD-B6)

Details

- Pneumatic shutter doors
- Zone Ring for station designation
- Standard fork lift pockets in base for easy movement
- Steel wall station divider
- Weight: Approx. 2500kg
- Maximum span: 1219.2mm (48")
- Maximum swing: 609.6mm (24")



Specifications:

Footprint Dimensions:
 Width: 2350mm (92.5")
 Height: 2329mm (91.7")
 Depth: 3200mm (126.0")

Manipulator Types:

- FD-V8
- FD-B6

Cell Options:

- 2 Stationary tables
- Positioner/Table
- 2 Positioners

Headstock Options:

- A2PB-250
- A2PB-500
- A2PB-1000

Available I/O Slots:

28 Inputs/26 Outputs
 (Additional Power Supply needed for Outputs)

Other Options:

- Access Door on RH Side
- Manual Sliding Door Assembly
- Station Lighting
- Torch Cleaning Station
- Extended I/O

ECO-ARC 290B

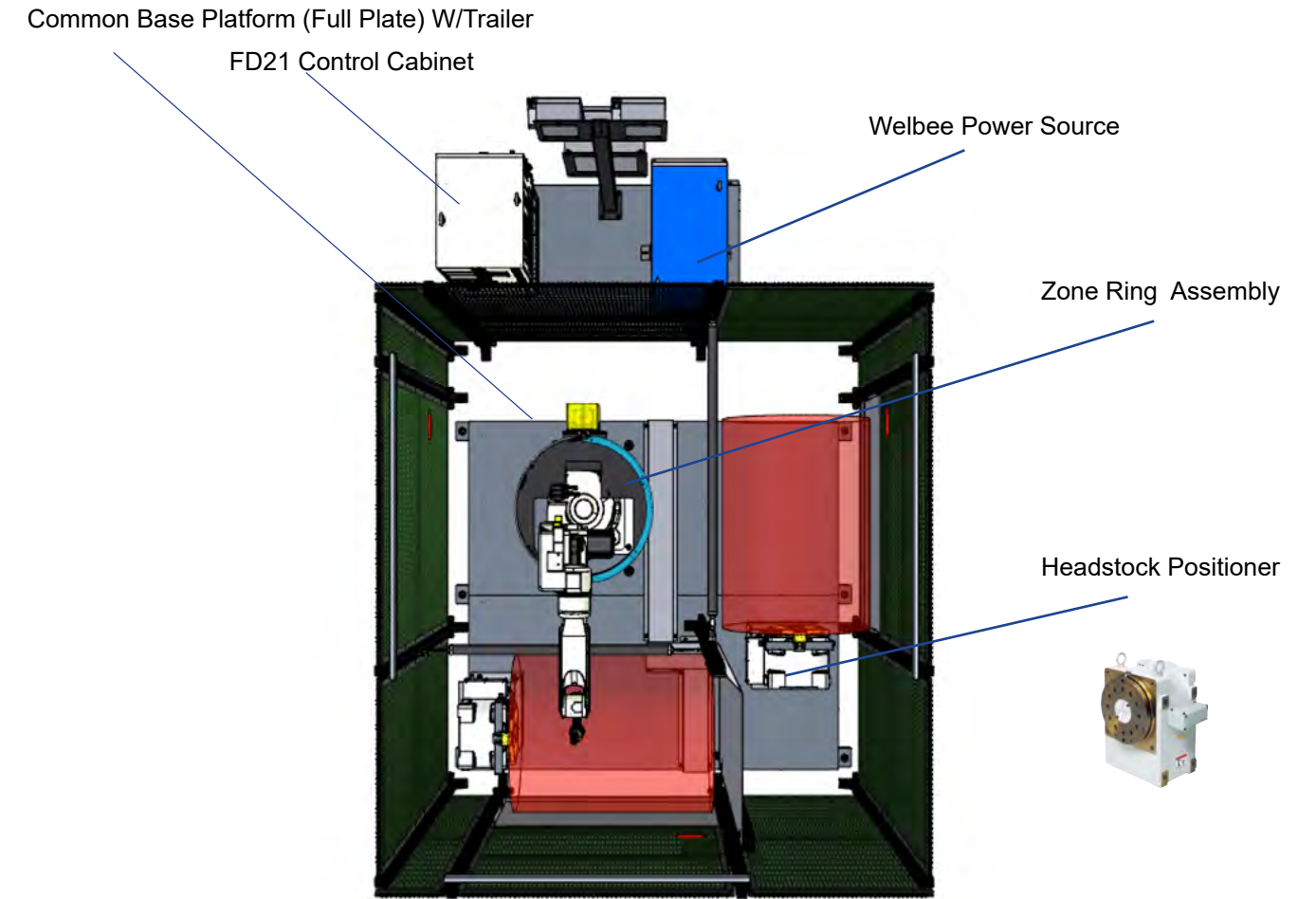
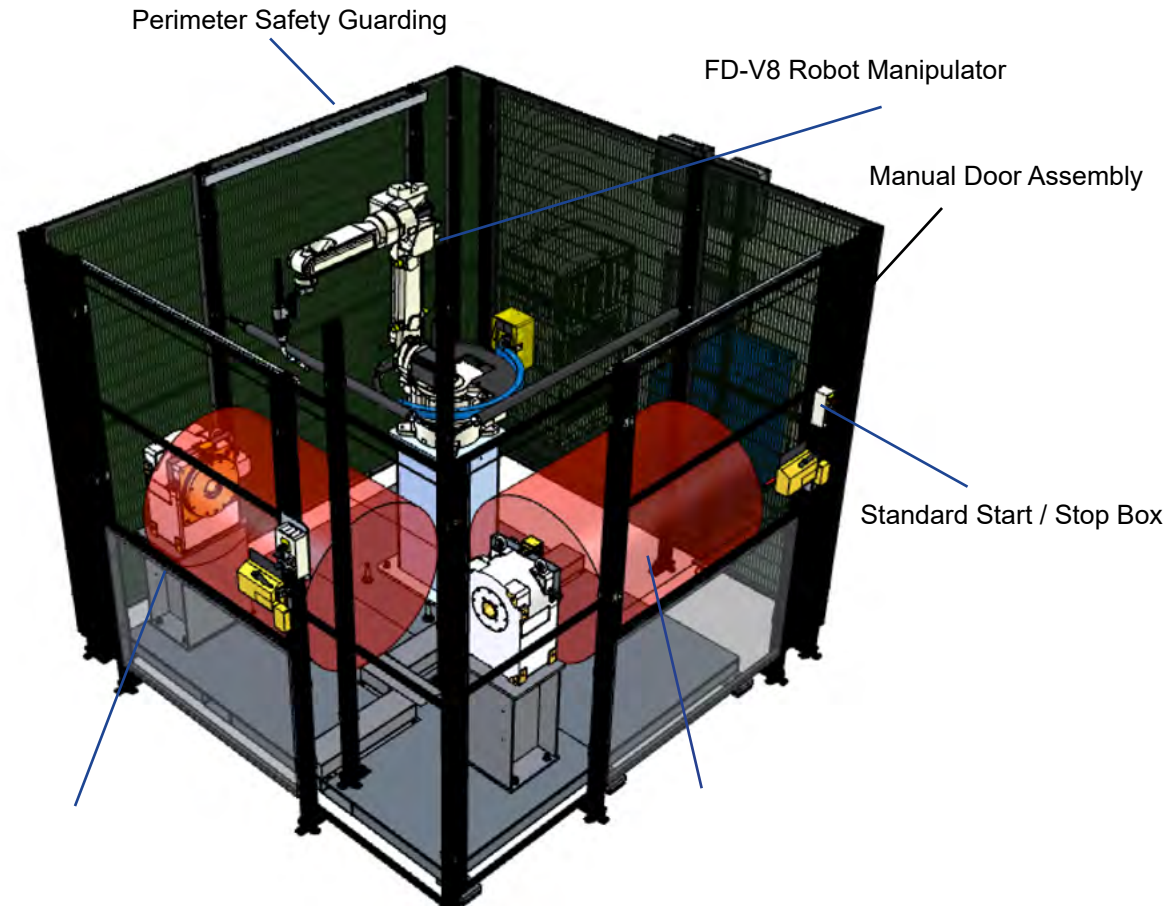

Standard Configuration:

ECO-ARC 290B

2 Servo-controlled headstocks with standard robot manipulator (FD-V8)

Details

- Pneumatic shutter doors
- Zone Ring for station designation
- Standard fork lift pockets in base for easy movement
- Steel wall station divider
- Weight: Approx. 2000kg
- Maximum span: 1016mm (40")
- Maximum swing: 762mm (30")



Specifications:

Footprint Dimensions:
 Width: 2590mm (102.0")
 Height: 2331mm (91.8")
 Depth: 3594mm (141.5")

Manipulator Types:

- FD-V8
- FD-B6

Cell Options:

- 2 Stationary tables
- Positioner/Table
- 2 Positioners

Headstock Options:

- A2PB-250
- A2PB-500
- A2PB-1000

Available I/O Slots:

28 Inputs/26 Outputs
 (Additional Power Supply needed for Outputs)

Other Options:

- Access Door on RH Side
- Station Lighting
- Torch Cleaning Station
- Extended I/O

ECO-ARC mini

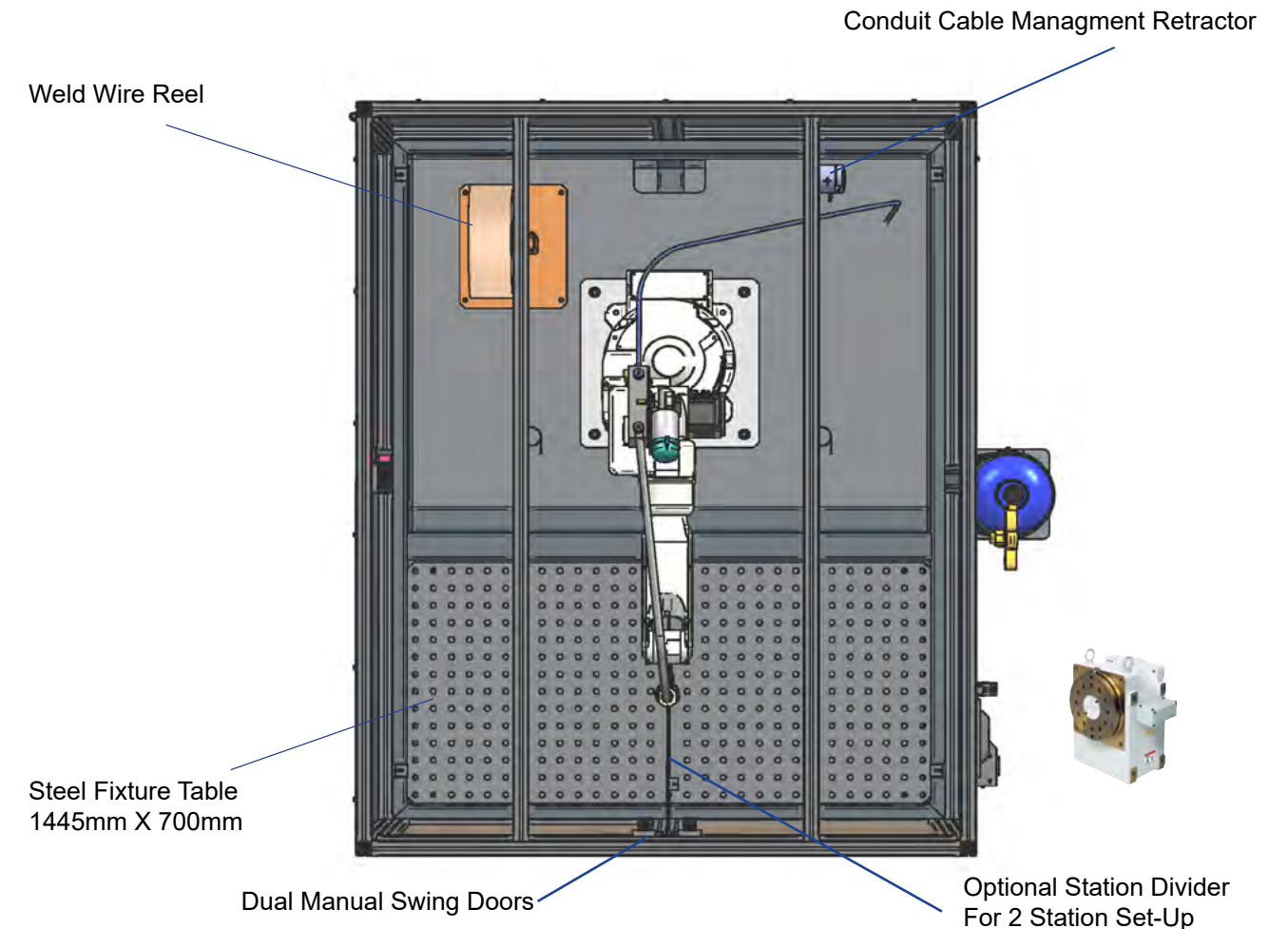
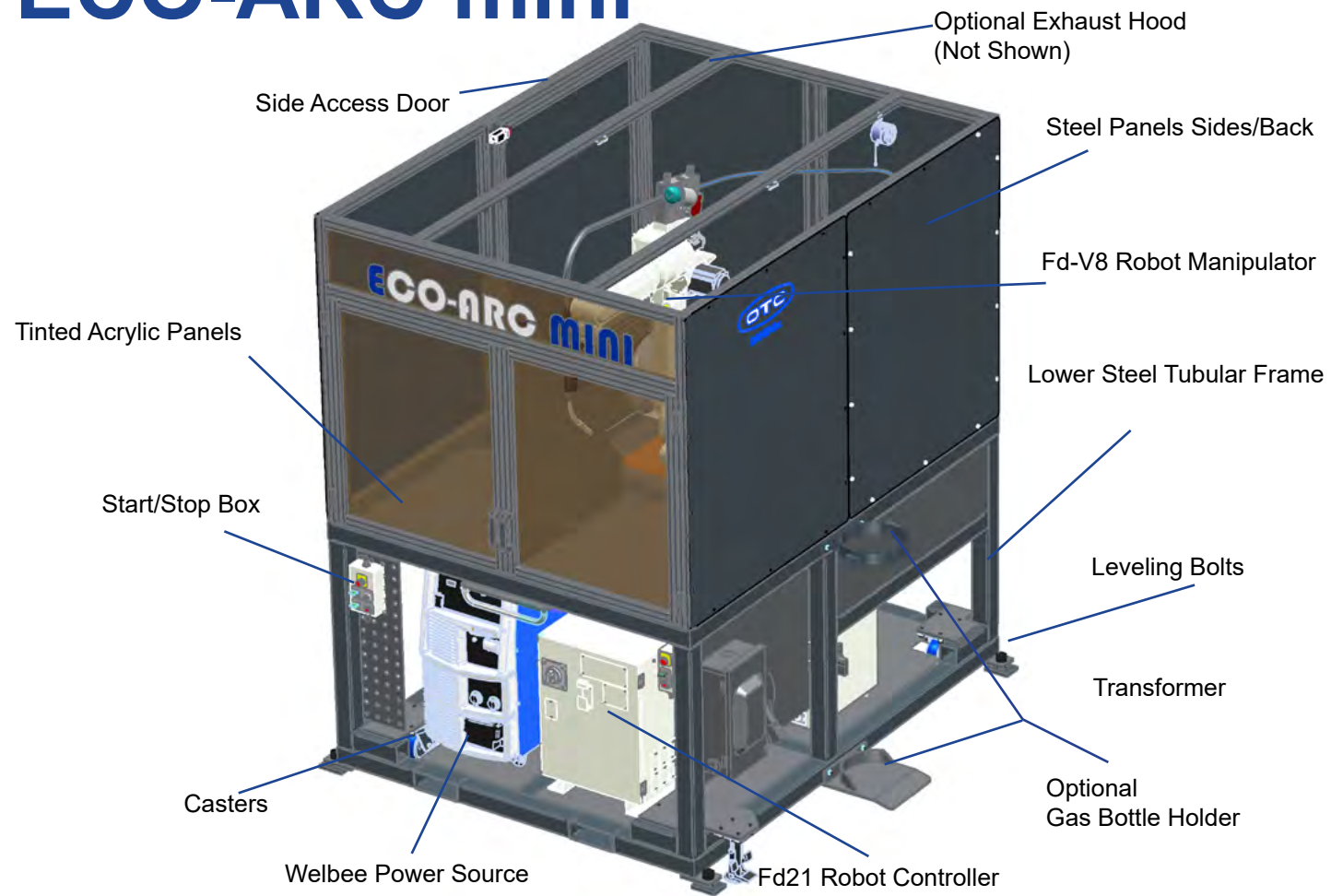

Standard Configuration:

ECO-ARC mini

Steel fixture with standard robot manipulator (FD-V8)

Details

- Dual Manual Swing Doors
- RMU for station designation
- Standard fork lift pockets in base for easy movement
- Steel wall station divider
- Weight: Approx. 1500kg
- Maximum width: 1400mm (55")
- Maximum Depth: 700mm (27.5")
- Station Lighting



FD-V8

Specifications:

Footprint Dimensions:

Width: 1650mm (65.0")
 Height: 2270mm (89.0")
 Depth: 2050mm (81.0")

Manipulator Types:

- FD-V8

Cell Options:

- 2 Station Divider
- Gas Bottle Holder
- Exhaust Fume Hood

Available I/O Slots:

28 Inputs/26 Outputs
 (Additional Power Supply needed for Outputs)

Other Options:

- Extended I/O
- Flextur 27 piece fixture kit

PT-ARC 600

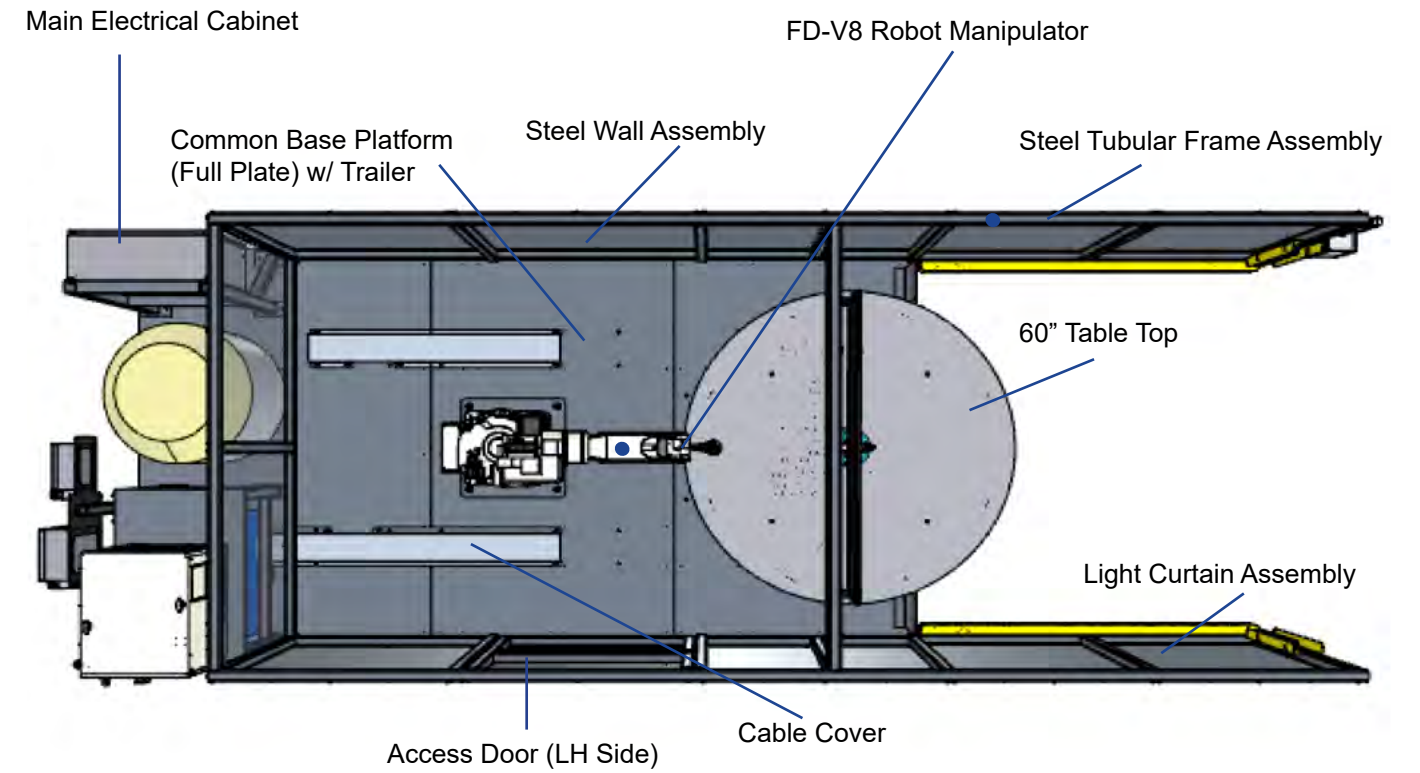
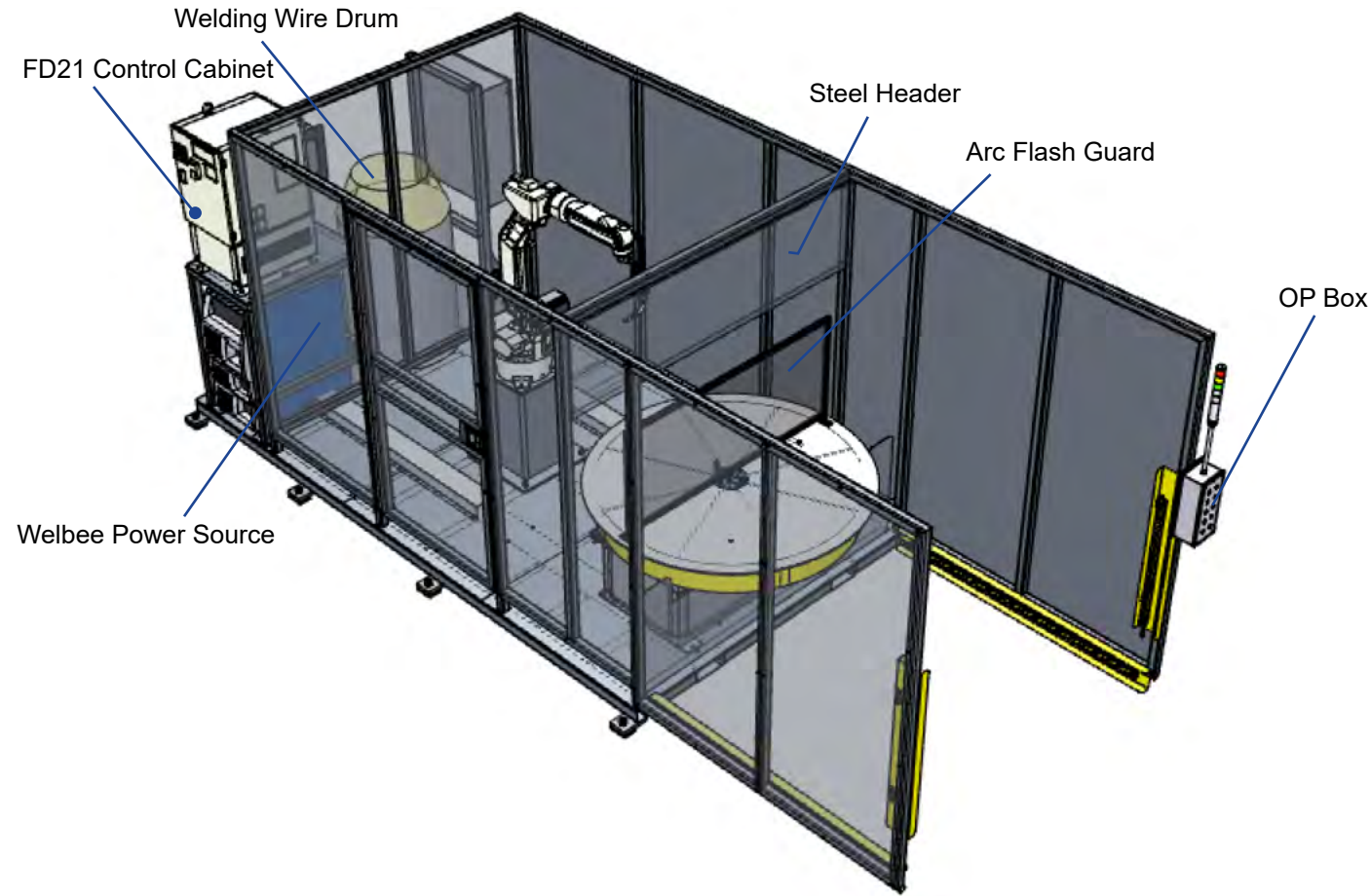

Standard Configuration:

PT-ARC 600
60" pneumatic indexing table

Details:

- Index Speed (180°) : 4.2 seconds
- Work Capacity: 250kg/side
- Weight: Approx. 3500kg
- Standard fork lift pockets
- Rack and Pinion Design



Specifications:

Footprint Dimensions:

Width: 2200mm (86.6")
Height: 2235mm (88.0")
Depth: 5511mm (217.0")

Manipulator Types:

- FD-V8
- FD-B6

Available I/O Slots:

22 Inputs/21 Outputs
(Additional Power Supply needed for Outputs)

Other Options:

- Fixture mounting pattern in table top
- Torch cleaning station
- Station lighting
- Access door on RH side
- Safety Fence on Full Base
- Basic Layout (PT-ARC 600B)
- Extended I/O

PT-ARC 600B

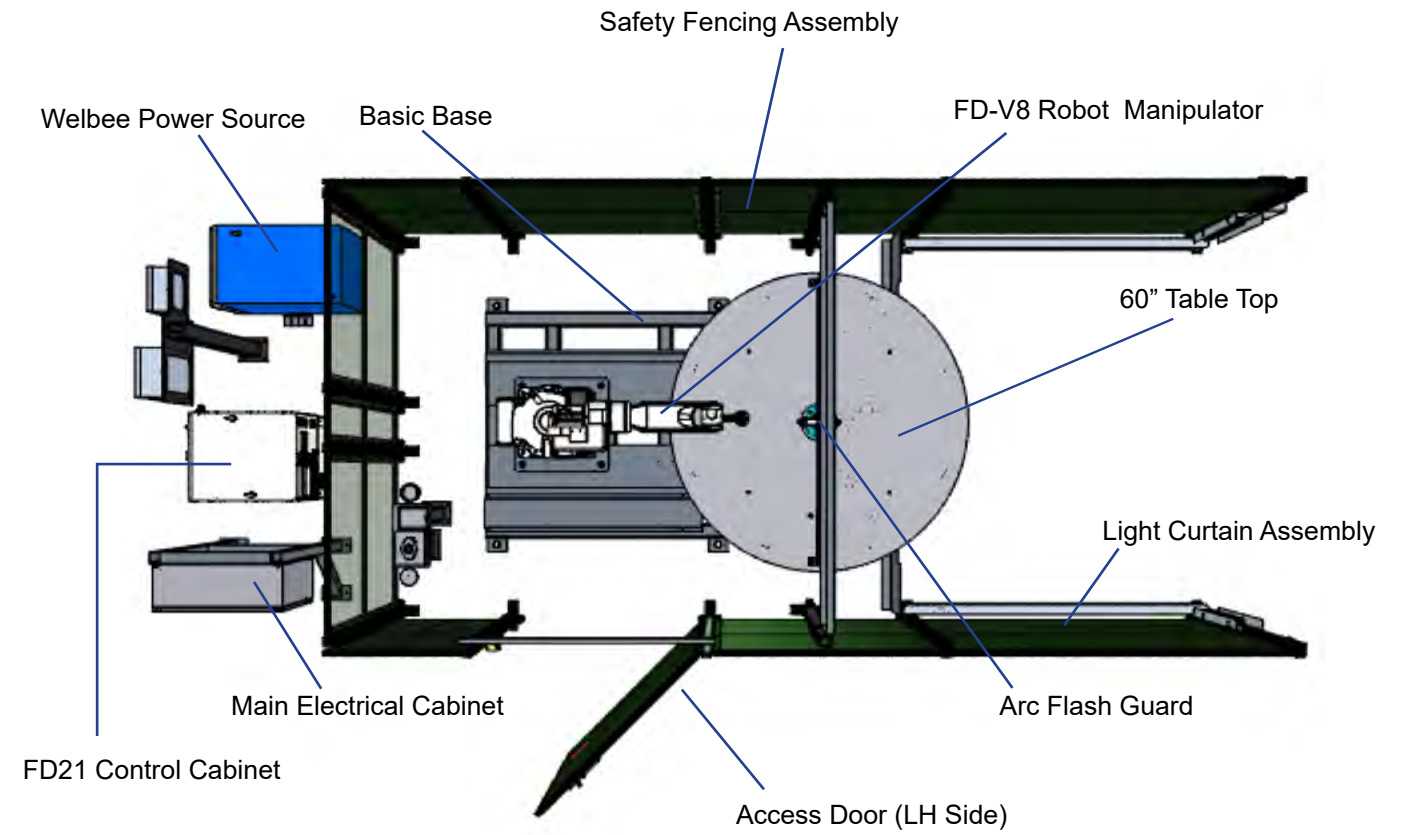
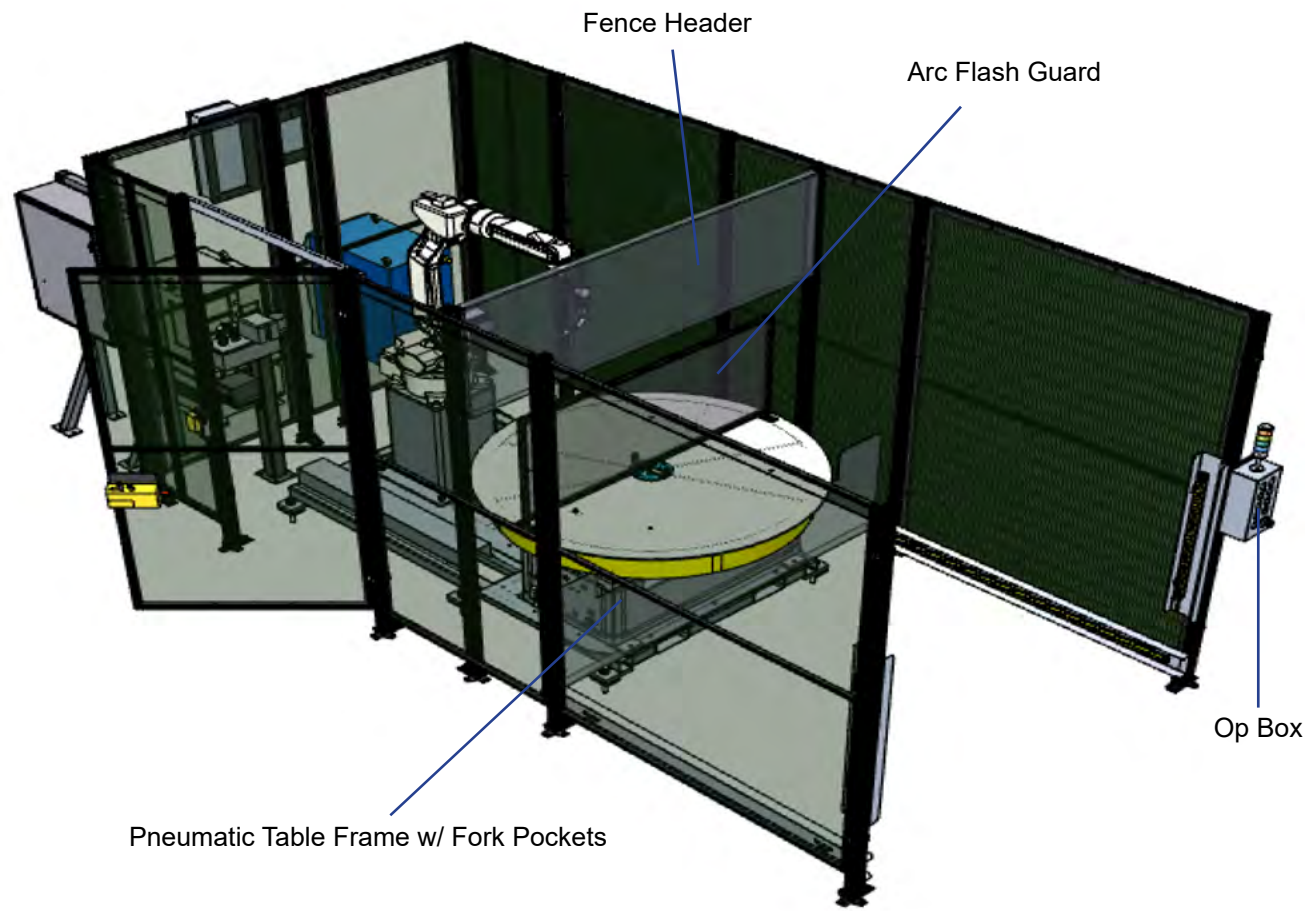

Standard Configuration:

PT-ARC 600B
60" pneumatic indexing table

Details:

- Index speed (180°): 4.2 seconds
- Work capacity: 250kg/side
- Weight: approx. 2000kg
- Standard fork lift pockets
- Rack and pinion design
- Floor mounted safety fencing w/ arc flash curtains



Specifications:

Footprint Dimensions:

Width: 2263mm (89.1")
Height: 2200mm (86.6")
Depth: 5406mm (212.8")

Manipulator Types:

- FD-V8
- FD-B6

Available I/O Slots:

28 Inputs/26 Outputs
(Additional Power Supply needed for Outputs)

Other Options:

- Fixture mounting pattern in table top
- Torch cleaning station
- Station Lighting
- Access door on RH side
- Standard Layout (PT-ARC 600)
- Extended I/O

SERVO-ARC 600

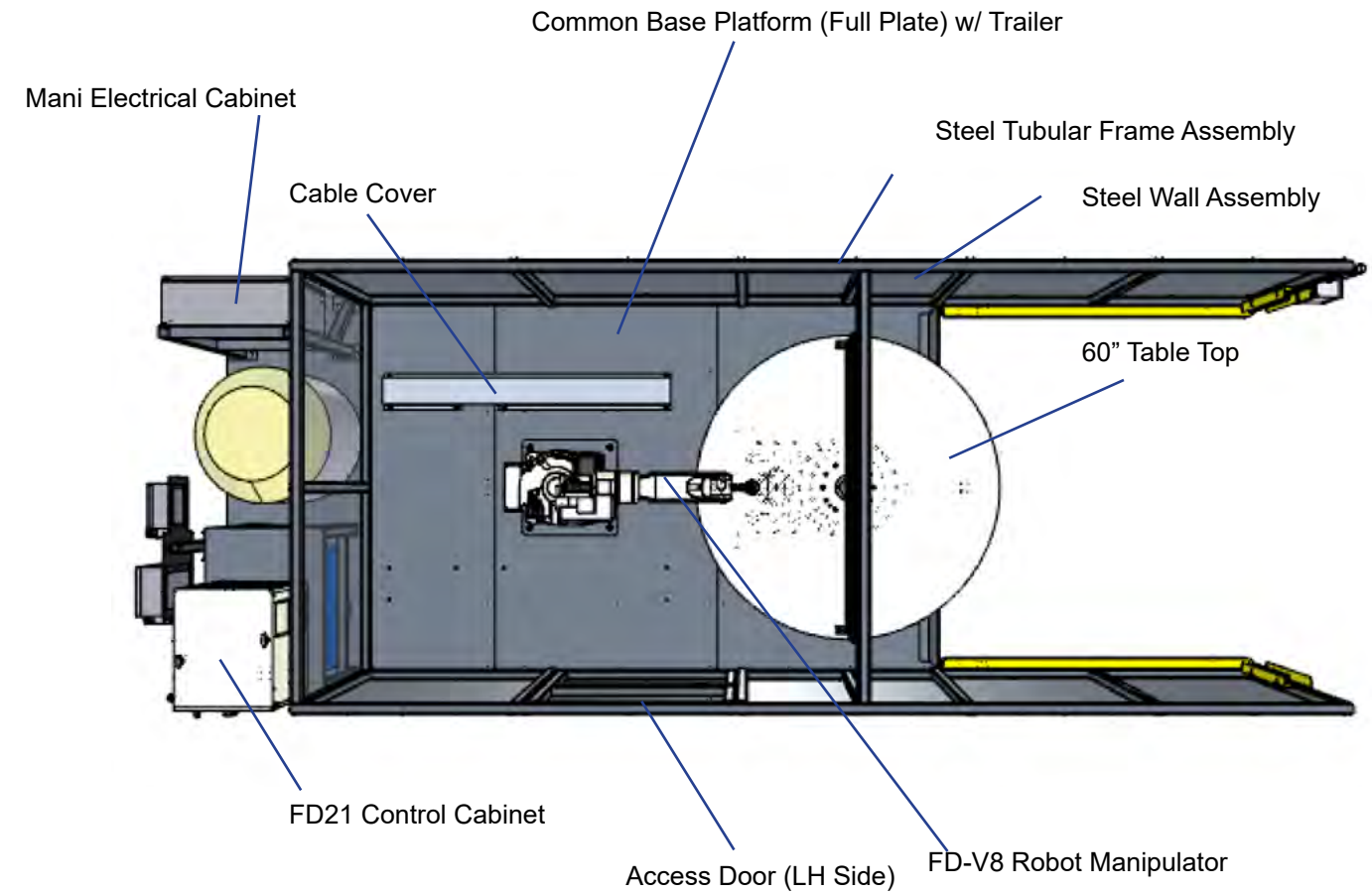
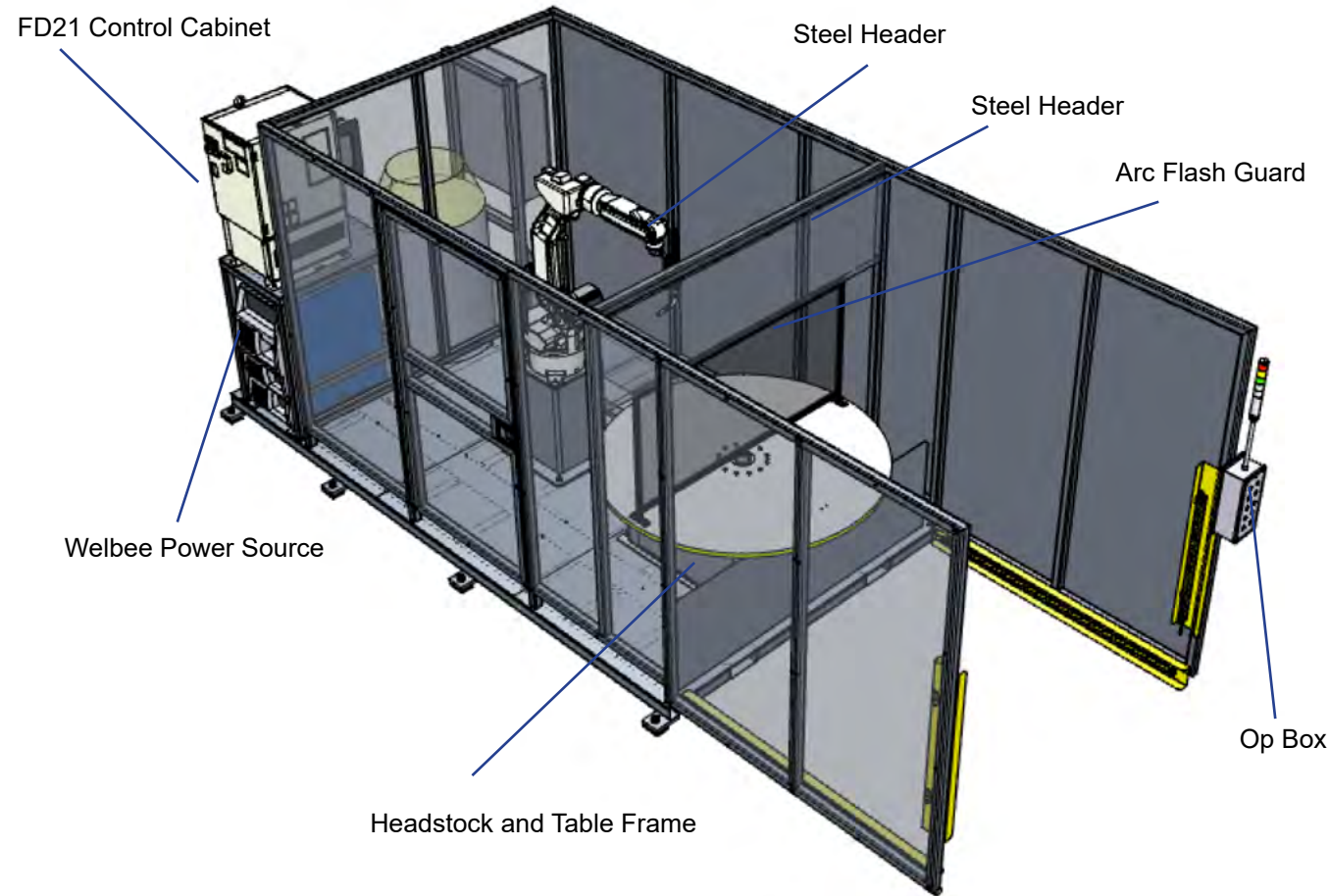

Standard Configuration:

SERVO-ARC 600

60" servo-driven indexing table

Details:

- 3" Through hole diameter in table top
- Index speed (180°) : 4.2 Seconds
- Work capacity: 250kg/side
- Weight: approx. 3000kg
- Standard fork lift pockets



Specifications:

Footprint Dimensions:

Width: 2200mm (86.6")
 Height: 2235mm (88.0")
 Depth: 5511mm (217.0")

Manipulator Types:

- FD-V8
- FD-B6

Available I/O Slots:

23 Inputs/24 Outputs
 (Additional Power Supply needed for Outputs)

Other Options:

- A2PB-1000 headstock instead of servo-table
- Fixture mounting pattern in table top
- Torch cleaning station
- Station lighting
- Access door on RH side
- Safety fence on full base
- Basic layout (servo-arc 600B)
- Extended i/o

SERVO-ARC 600B

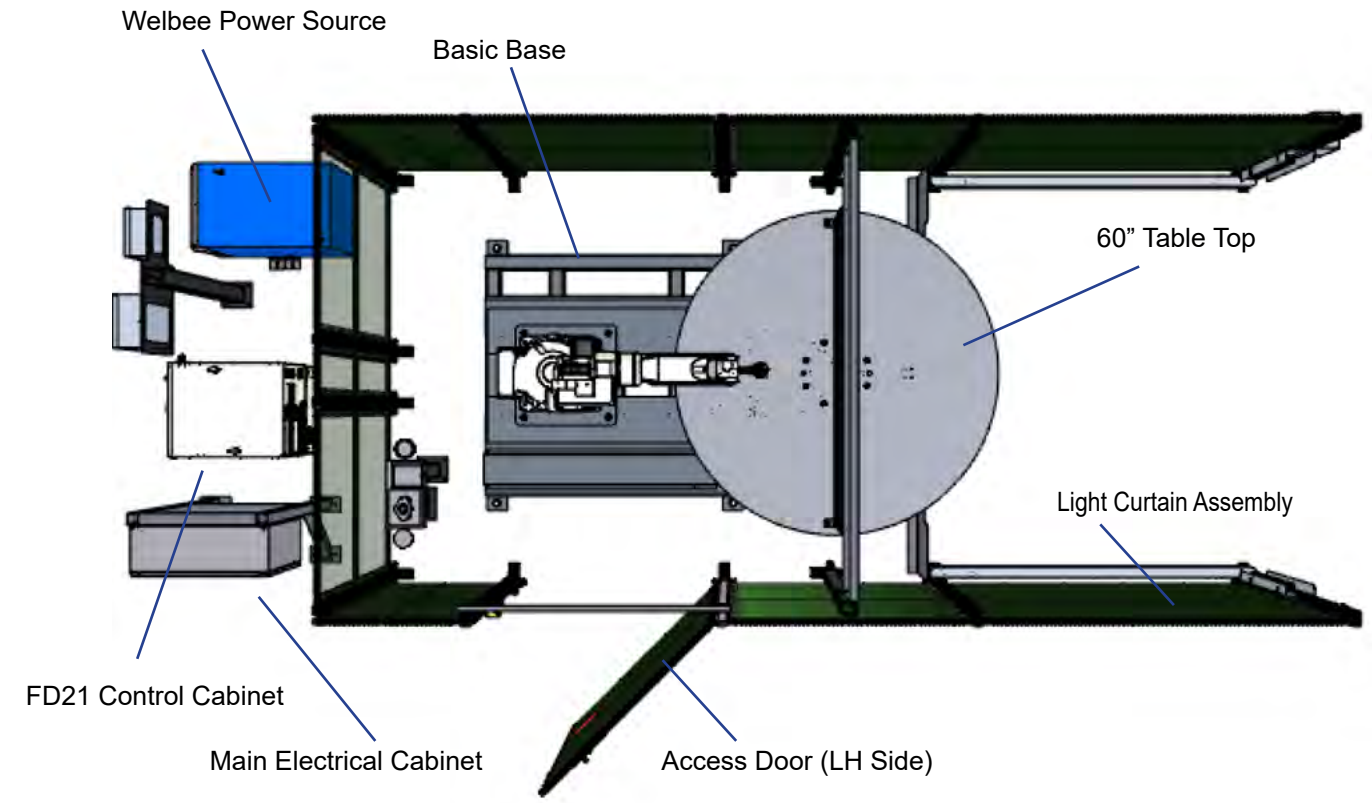
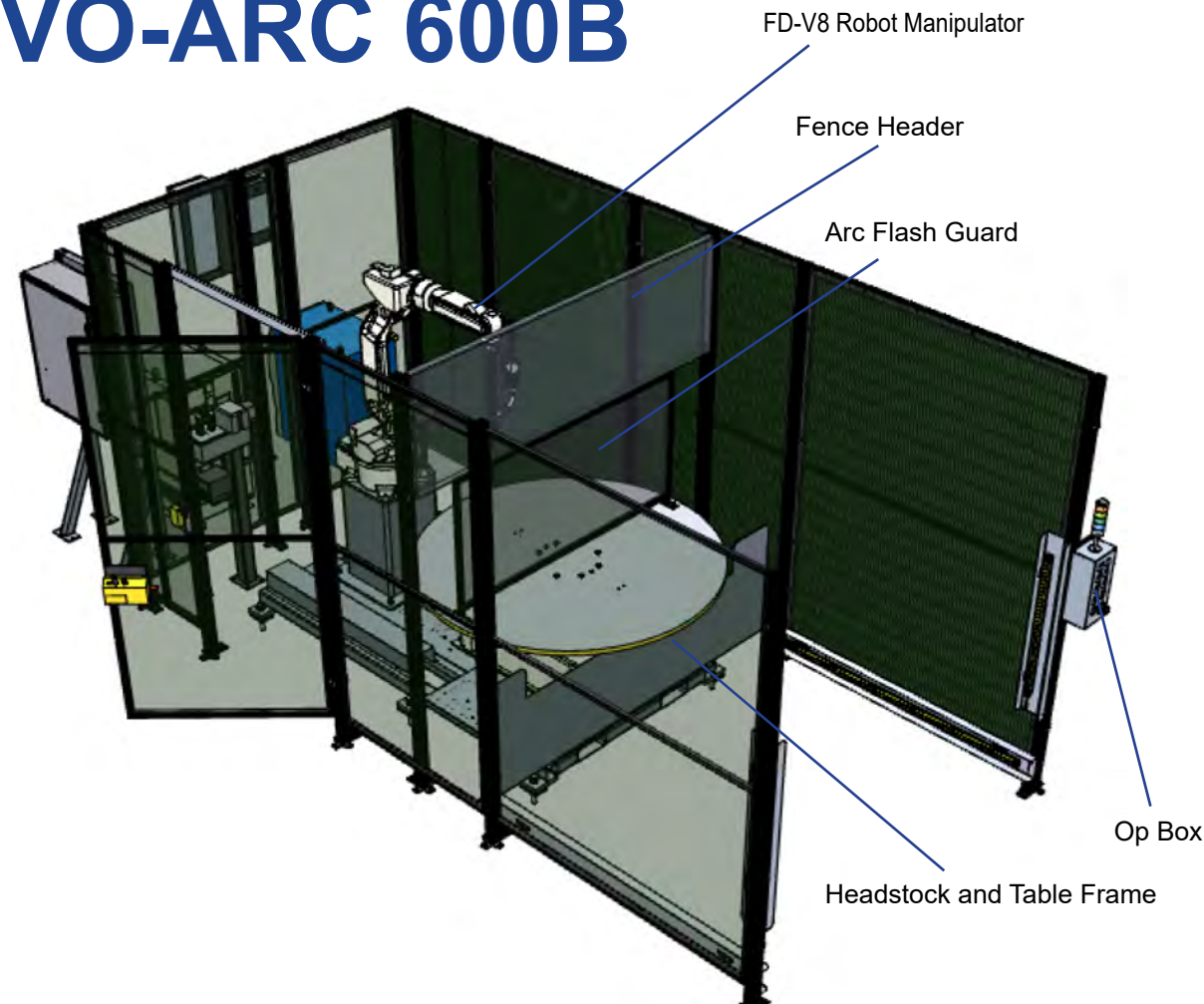

Standard Configuration:

SERVO-ARC 600B

60" servo-driven indexing table

Details:

- 3" Through hole diameter in table top
- Index speed (180°): 4.2 Seconds
- Work capacity: 250 kg/side
- Weight: approx. 2000kg
- Standard fork lift pockets
- A2PB-1000 headstock instead of servo-table
- Floor mounted safety fencing w/ arc flash curtains



FD-V8



FD-B6

Specifications:

Footprint Dimensions:

- Width: 2263mm (89.1")
- Height: 2200mm (86.6")
- Depth: 5406mm (212.8")

Manipulator Types:

- FD-V8
- FD-B6

Available I/O Slots:

23 Inputs/24 Outputs
(Additional Power Supply needed for Outputs)

Other Options:

- Fixture mounting pattern in table top
- Torch cleaning station
- Station lighting
- Access door on rh side
- Safety fence on full base
- Standard layout (servo-arc 600)
- Extended i/o
- Trailer (base)

SERVO-ARC 720

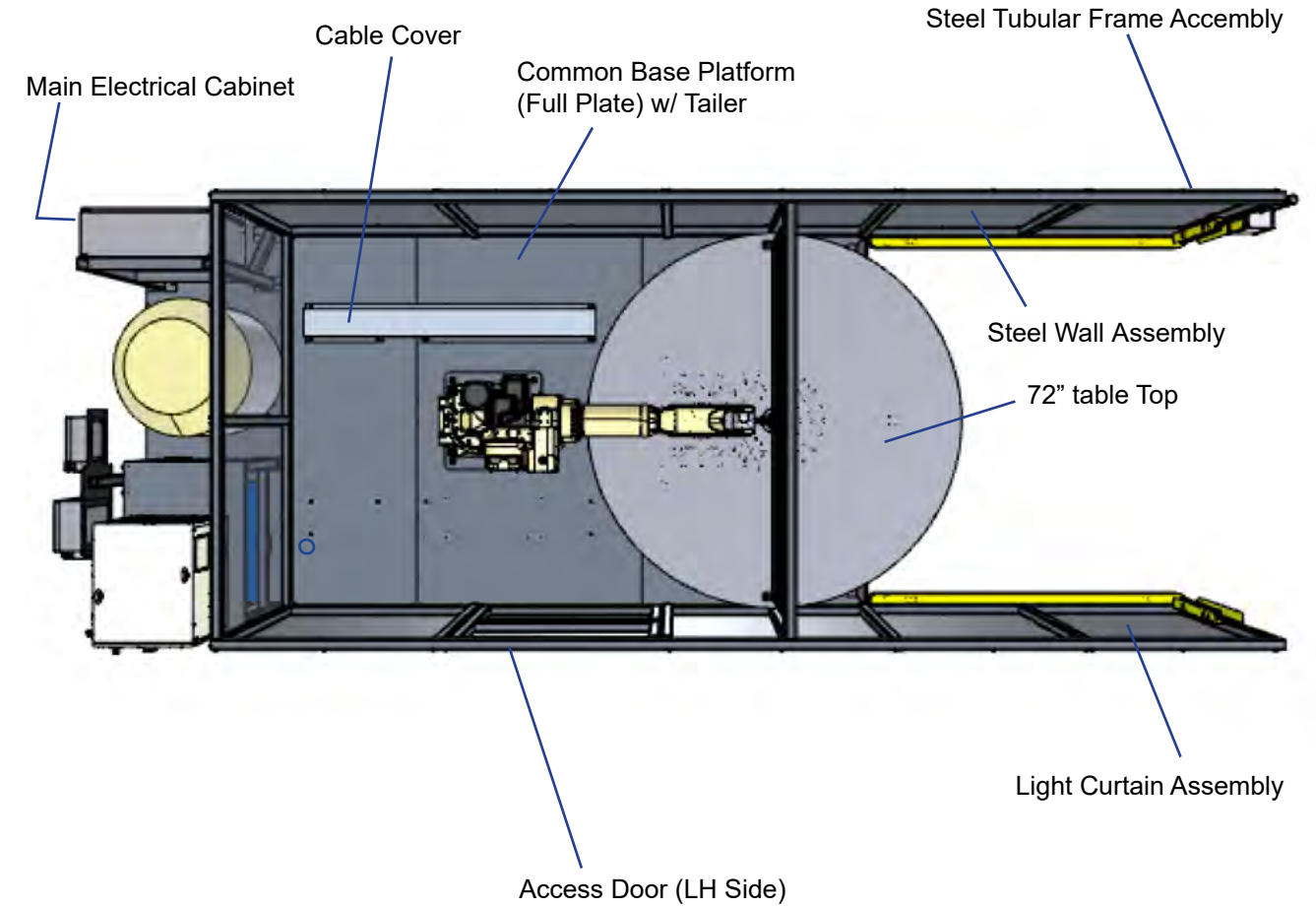
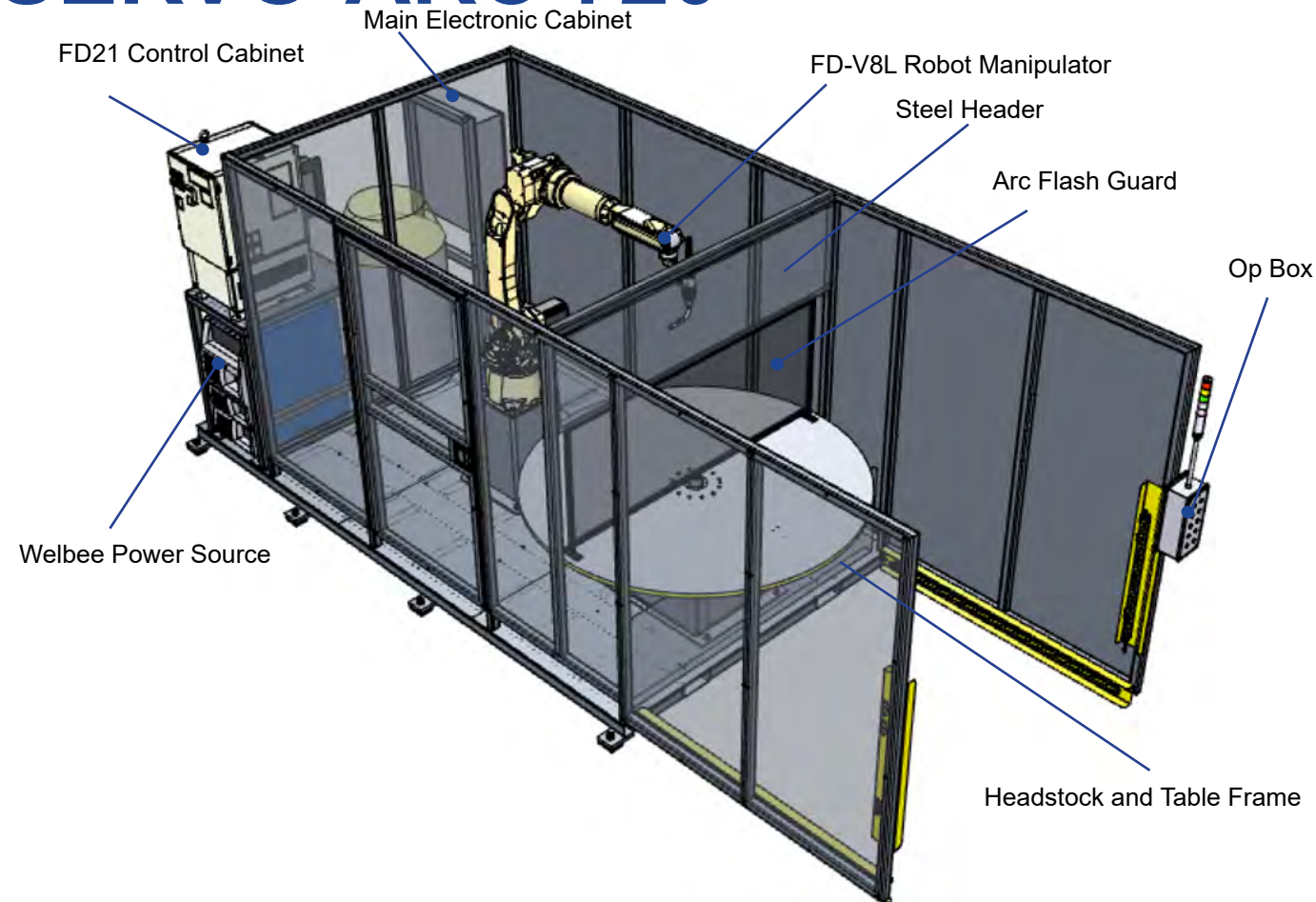

Standard Configuration:

SERVO-ARC 720

72" servo-driven indexing table

Details:

- 3" through hole diameter in table top
- Index Speed (180°): 4.2 seconds
- Work capacity: 250kg/side
- Weight: approx. 3200kg
- Standard fork lift pockets



FD-V8L-S2

FD-B6L-S2

Specifications:

Footprint Dimensions:

Width: 2200mm (86.6")
 Height: 2235mm (88.0")
 Depth: 5511mm (217.0")

Manipulator Types:

- FD-V8
- FD-V8L-S2
- FD-B6
- FD-B6L-S2

Available I/O Slots:

23 Inputs/24 Outputs
 (Additional Power Supply needed for Outputs)

Other Options:

- A2PB-1000 Headstock instead of servo-table
- Fixture mounting pattern in table top
- Torch cleaning station
- Station Lighting
- Access door on RH side
- Safety Fence on Full Base
- Dual manipulators
- Basic layout (SERVO-ARC 720B)
- Extended I/O

SERVO-ARC 720B

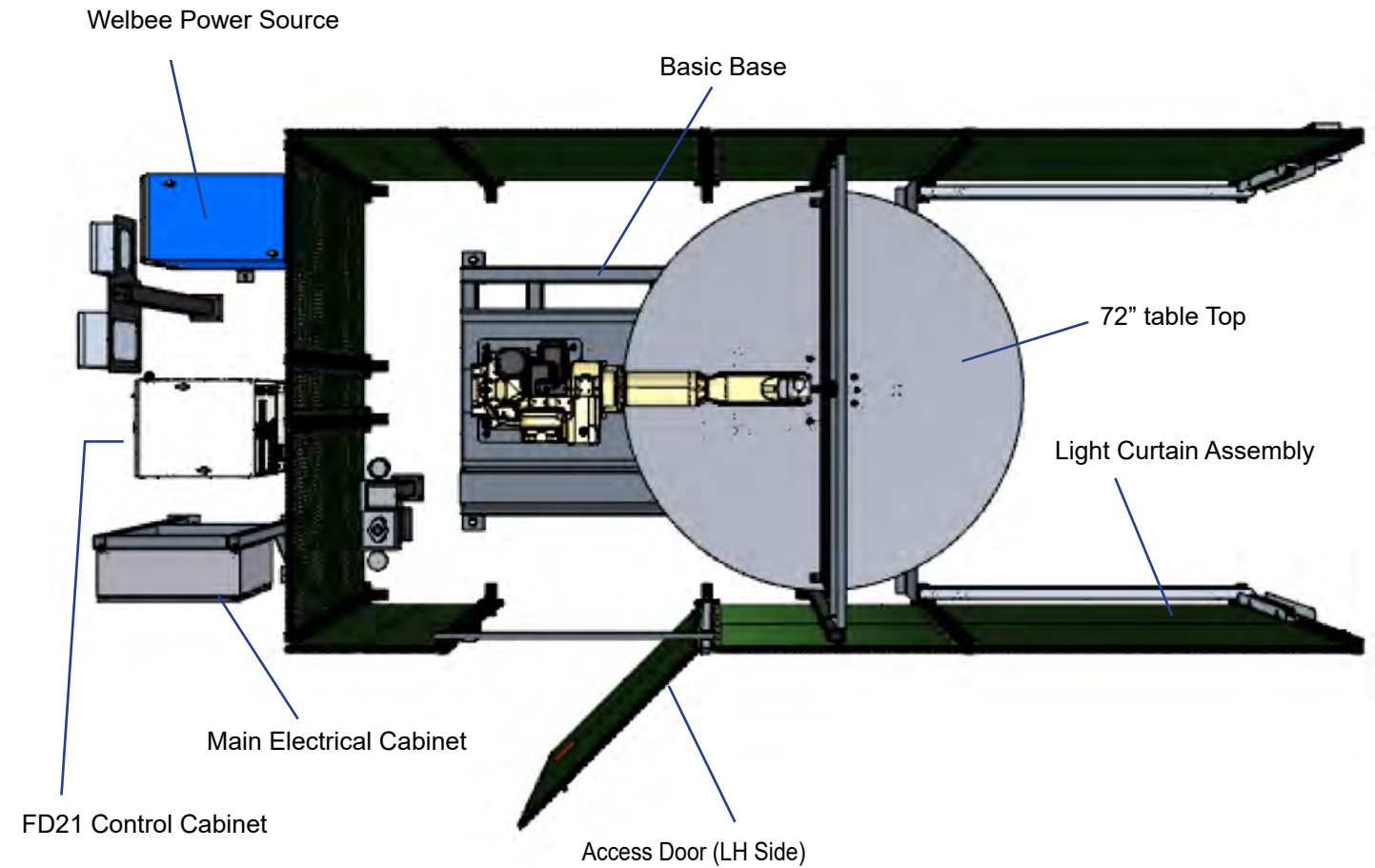
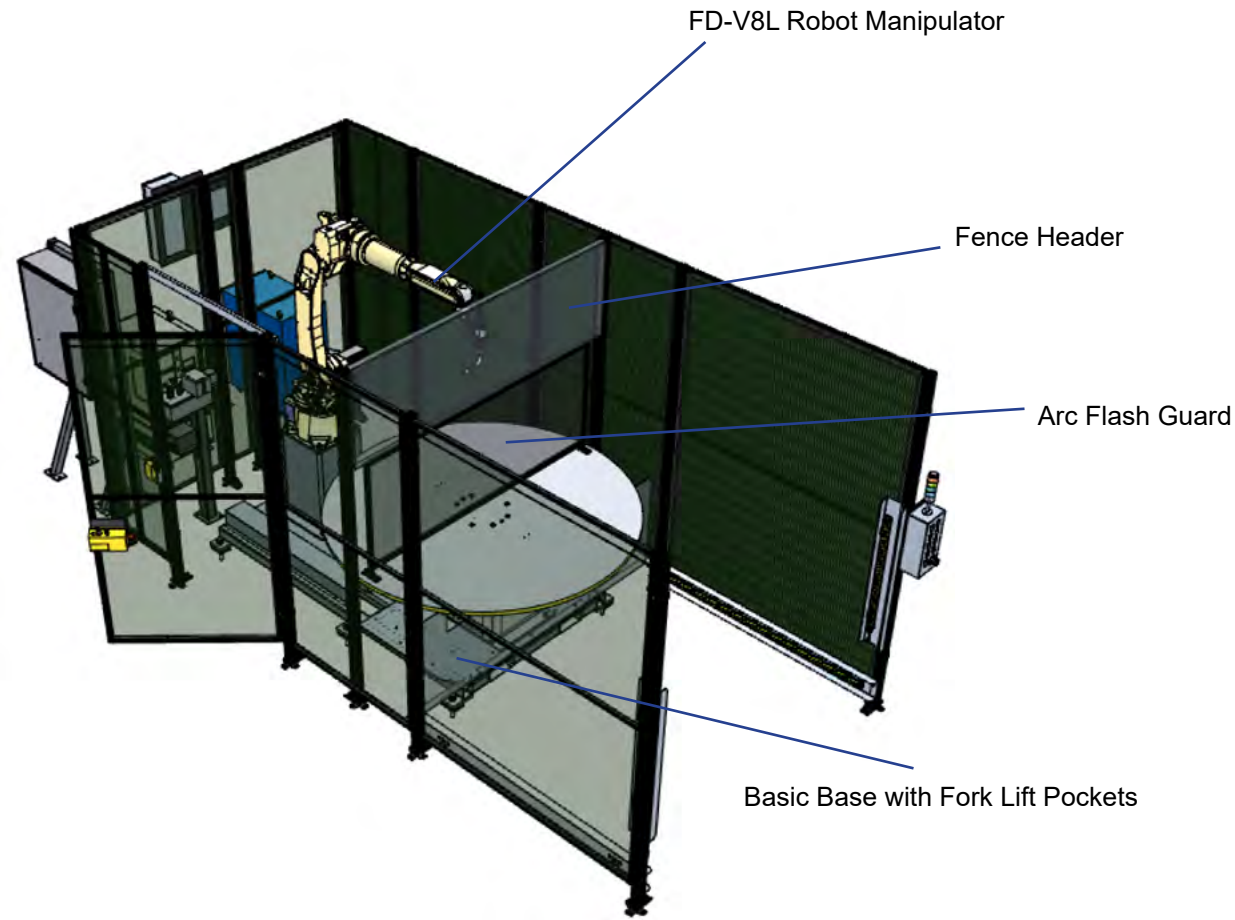

Standard Configuration:

SERVO-ARC 720B

72" servo-driven indexing table

Details:

- 3" through hole diameter in table top
- Index speed (180°) : 4.2 Seconds
- Work capacity: 250 kg/side
- Weight: approx. 2200 kg
- Standard fork lift pockets
- A2PB-1000 headstock instead of servo-table
- Floor mounted safety fencing w/ arc flash curtains

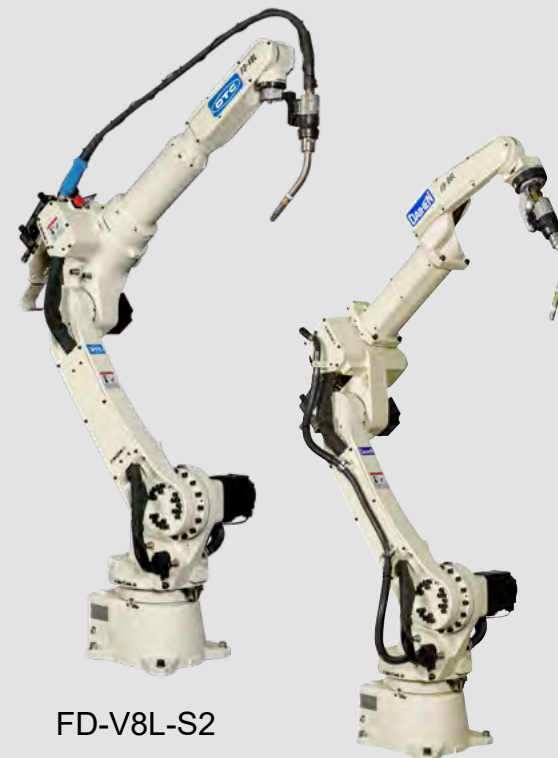

FD-V8L-S2

FD-B6L-S2

Specifications:

Footprint Dimensions:

- Width: 2187mm (86.1")
- Height: 2200mm (86.6")
- Depth: 4564mm (179.7")

Manipulator Types:

- FD-V8
- FD-V8L-S2
- FD-B6
- FD-B6L-S2

Available I/O Slots:

23 Inputs/24 Outputs
(Additional Power Supply needed for Outputs)

Other Options:

- Fixture mounting pattern in table top
- Torch cleaning station
- Station Lighting
- Access door on RH side
- Safety Fence on Full Base
- Dual manipulators
- Basic layout (SERVO-ARC 720B)
- Extended I/O

DT-ARC 500

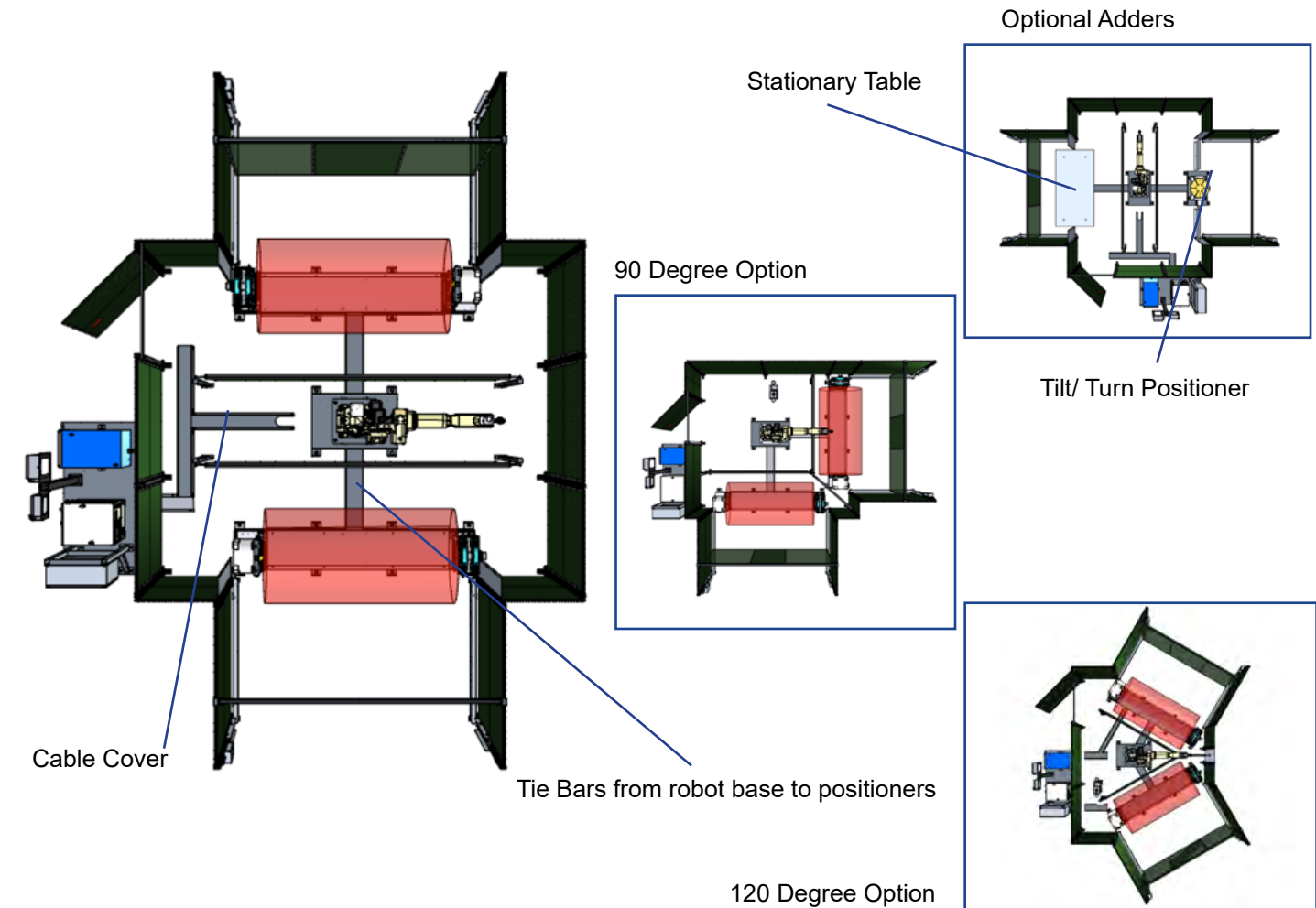
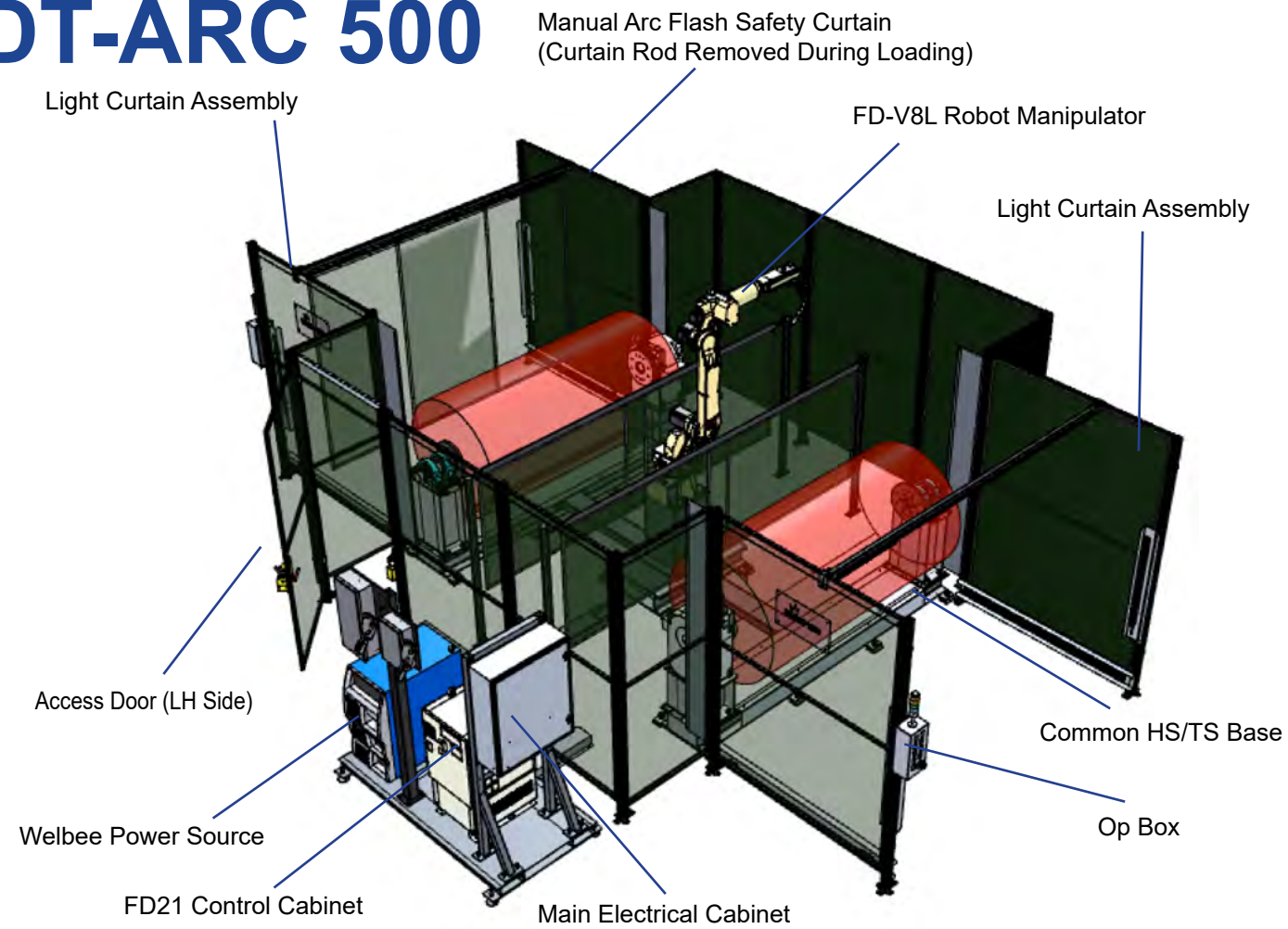

Standard Configuration:

DT-ARC 500
Dual Servo-controlled head and tailstock positioning cell

Details:

- Dual A2PB-500 headstock positioners
- Work Capacity: 500kg/side
- Manual arc flash safety curtain at individual operator stations
- Weight: Approx. 3000kg
- Common base for HS/TS Assembly
- Three part base connected with tie bars
- Standard HS/TS span: 2000mm
- Maximum span: 3100mm
- HS/TS swing diameter: 1000mm
- Zone ring for station designation
- Access door on LH side
- Arc flash curtain for cross station protection
- Floor mounted safety fencing w/ arc flash curtains

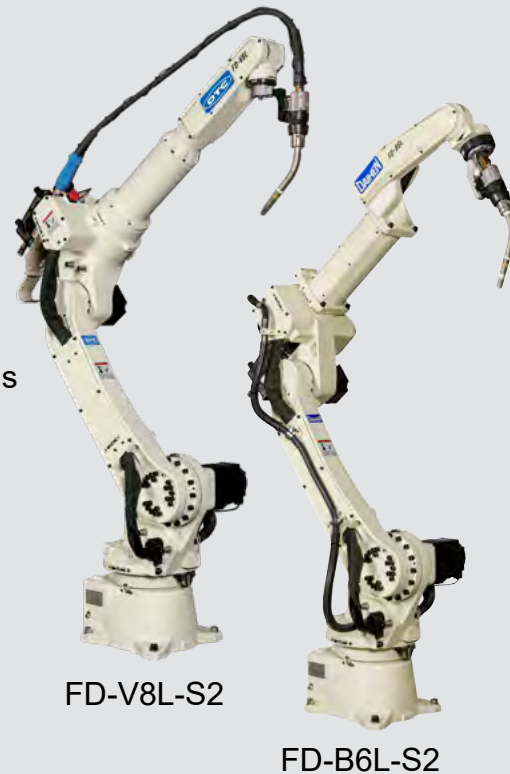

Specifications

Footprint Dimensions:

- Width: 5556mm (218.7")
- Height: 2200mm (86.6")
- Depth: 7055mm (277.8")



Manipulator Types:

- FD-V8L-S2
- FD-B6L-S2

Cell Options:

- Stationary table(s)
- H/S-T/S assembly(s)
- Tilt/Turn positioner(s)

Headstock Options:

- A2PB-250
- A2PB-1000

Tilt/Turn Options:

- A2PF-300
- A2PF-500
- A2PF-1000

Available I/O Slots:

15 Inputs/24 Outputs
(Additional Power Supply needed for Outputs)

Other Options:

- Roll up arc flash door at individual operator stations –OTC design or RiteHite
- Full Base w/ steel wall assembly
- 120° configuration
- Torch cleaning station
- Access door on RH side
- Utility trailer
- Multiple manipulators w/ platform (connected with tie bars)
- Extended I/O
- 90 Degree configuration

ROTA-ARC 250

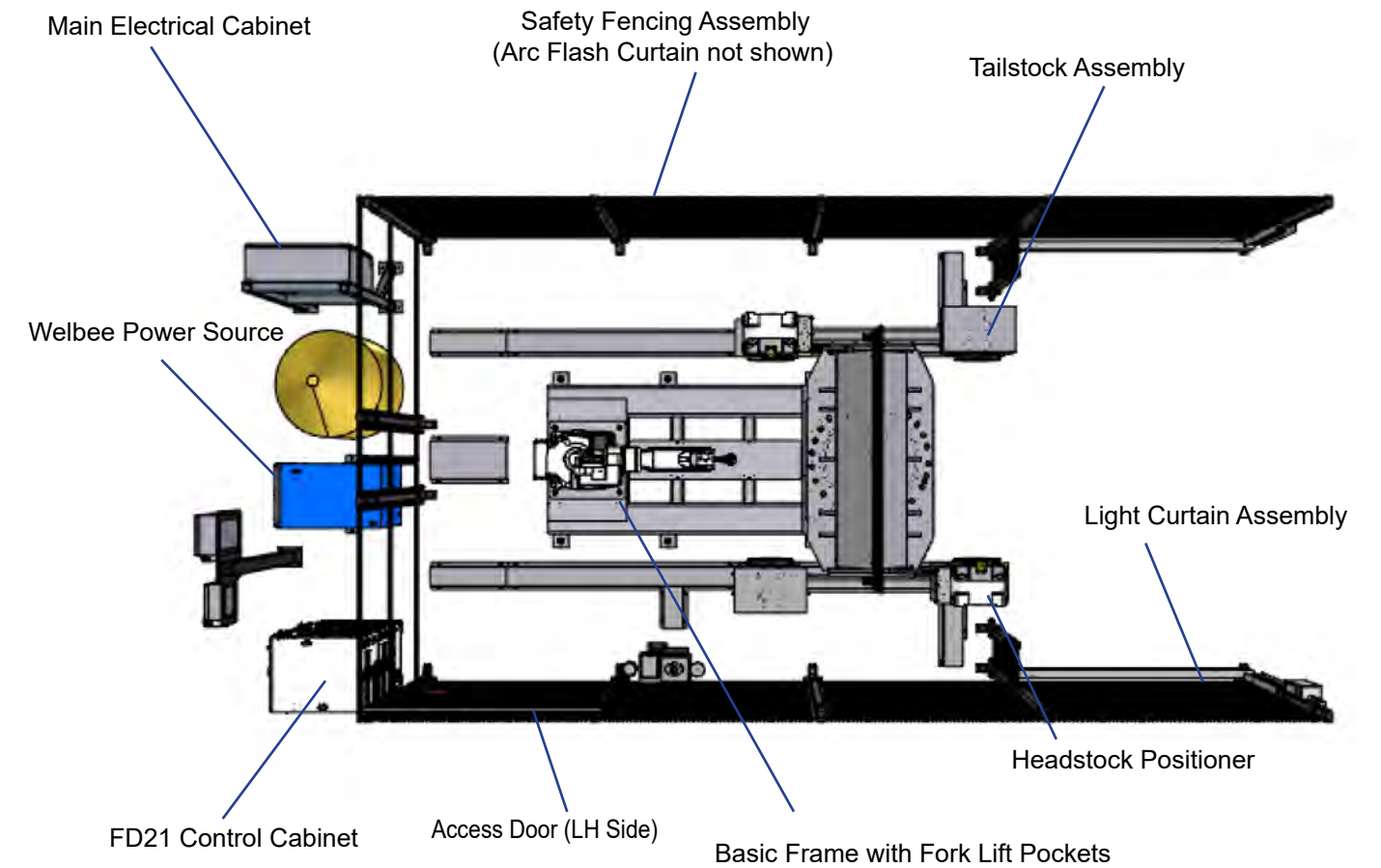
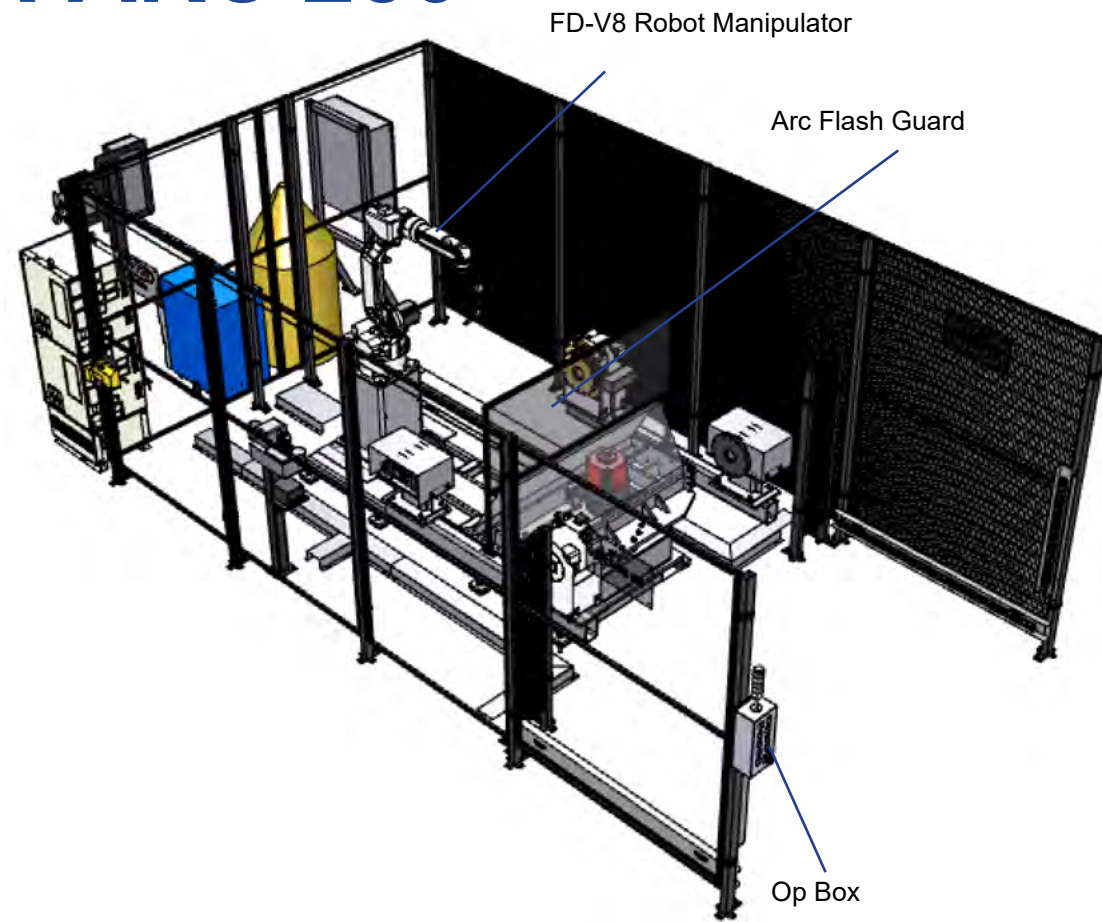

Standard Configuration:

ROTA-ARC 250

3 Axis Rotary Positioner with (2) Headstock/Tailstock Stations

Details:

- 3-Axis, Servo-controlled Positioner
- Work Capacity: 250kg / side
- Weight: Approx. 4000kg
- Standard fork lift pockets in base
- Standard HS/TS span: 1500mm
- Index Speed: 5 seconds
- HS/TS swing diameter: 900mm
- Floor mounted safety fencing w/ arc flash curtains
- Utility trailer



FD-V8



FD-B6

Specifications:

Footprint Dimensions:

Width: 3347 mm (131.8")
 Height: 2200mm (86.6")
 Depth: 6732mm (265.0")

Manipulator Types:

- FD-V8
- FD-V8L-S2
- FD-B6
- FD-B6L-S2

Available I/O Slots:

21 Inputs/29 Outputs
 (Additional Power Supply needed for Outputs)

Other Options:

- HS/TS span of 1500mm max.
- Torch cleaning station
- Access door on RH side
- Multiple manipulators
- Extended I/O (recommended)

ROTA-ARC 500

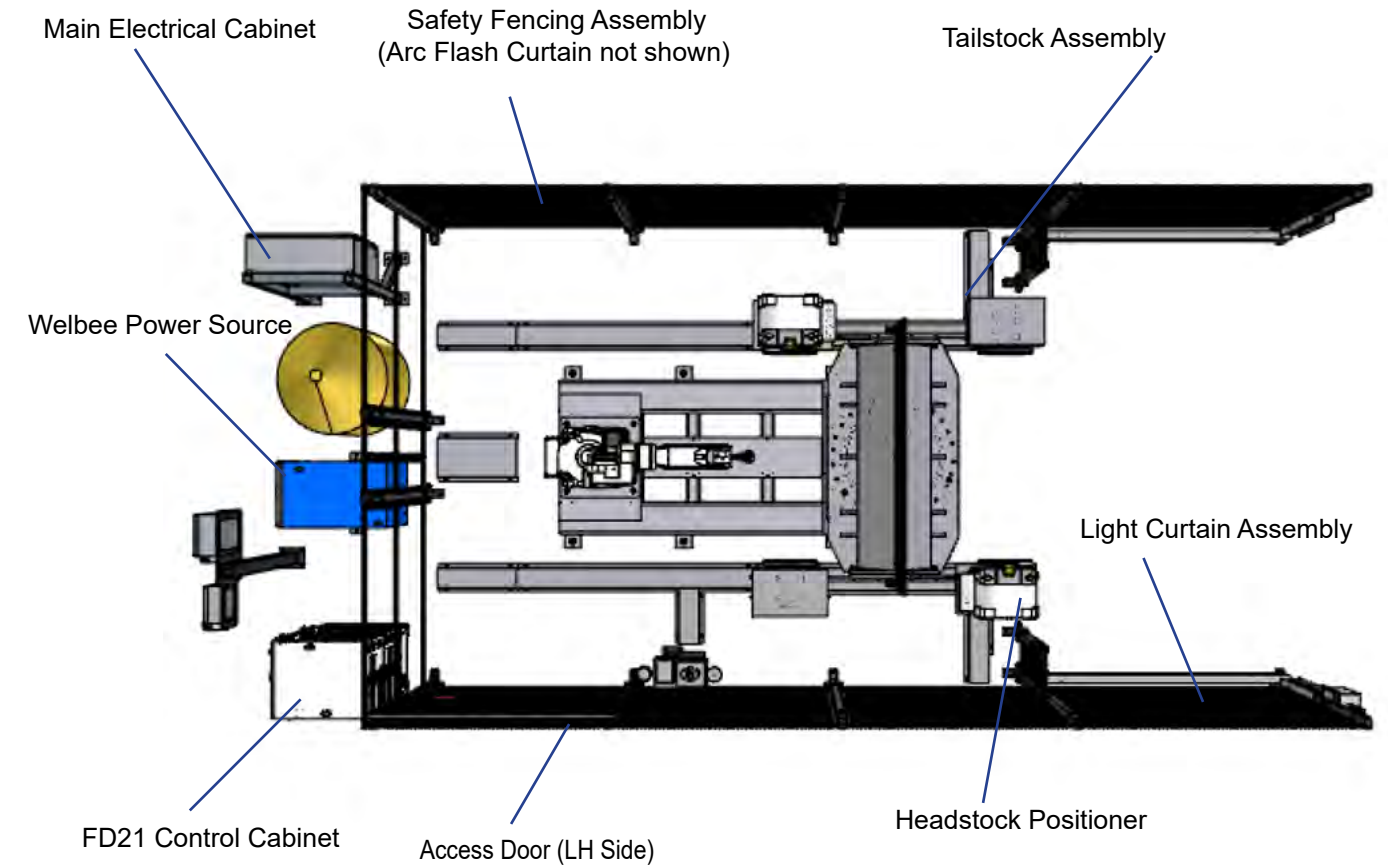
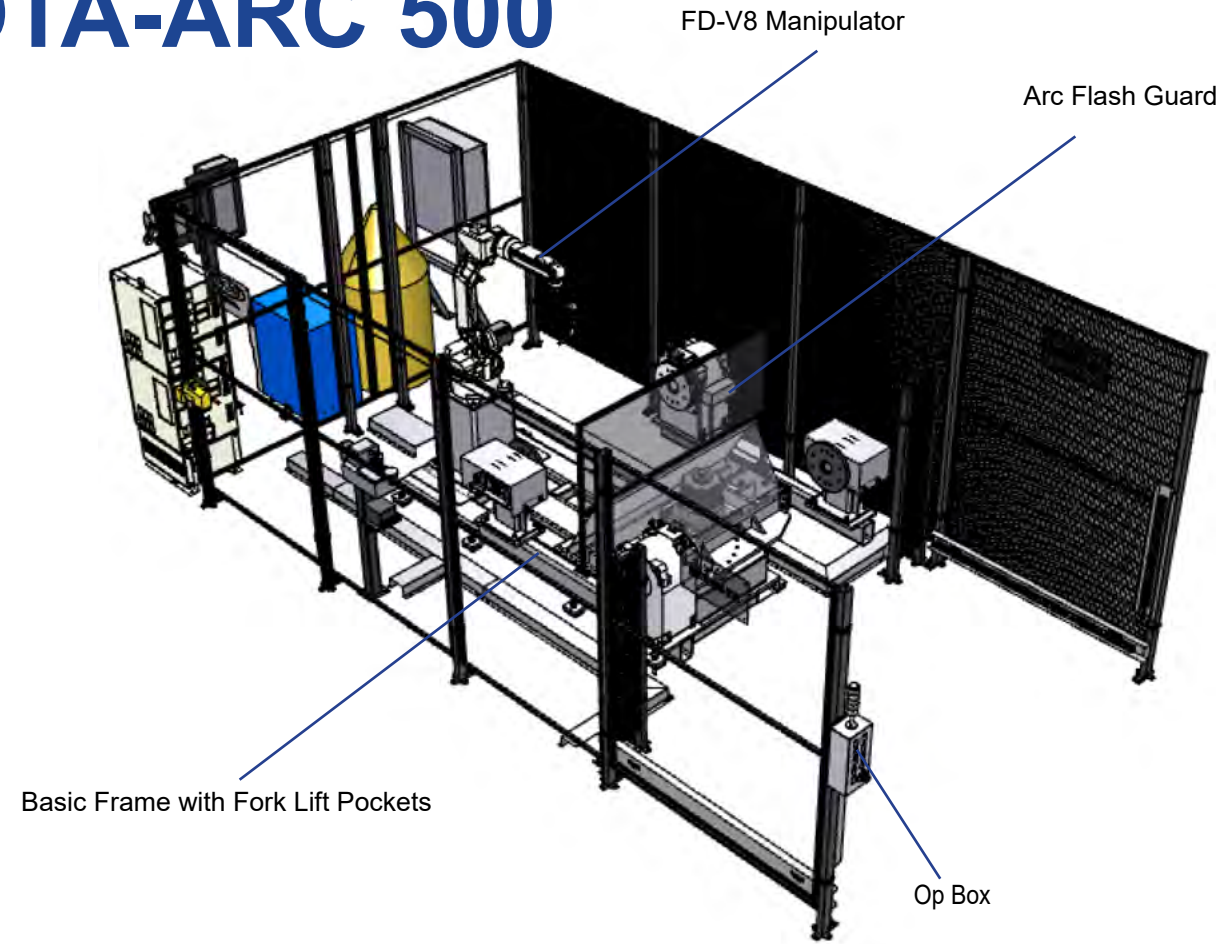

Standard Configuration:

ROTA-ARC 500

3 Axis Rotary Positioner with (2) Headstock/Tailstock Stations

Details:

- 3-Axis, Servo-controlled Positioner
- Work Capacity: 500kg / side
- Weight: Approx. 4250kg
- Standard fork lift pockets in base
- Standard HS/TS span: 1500mm
- Index Speed: 5 seconds
- HS/TS swing diameter: 900mm
- Floor mounted safety fencing w/ arc flash curtains
- Utility trailer



FD-V8



FD-B6

Specifications:

Footprint Dimensions:

Width: 3347mm (131.8")
 Height: 2200mm (86.6")
 Depth: 6732mm (265.0")

Manipulator Types:

- FD-V8
- FD-V8L-S2
- FD-B6
- FD-B6L-S2

Available I/O Slots:

21 Inputs / 29 Outputs
 (Additional Power Supply needed for Outputs)

Other Options:

- HS/TS span of 1500mm max.
- Torch cleaning station
- Access door on RH side
- Multiple manipulators
- Extended I/O (recommended)

ROTA-ARC 1000

FD-V8L Robot Manipulator

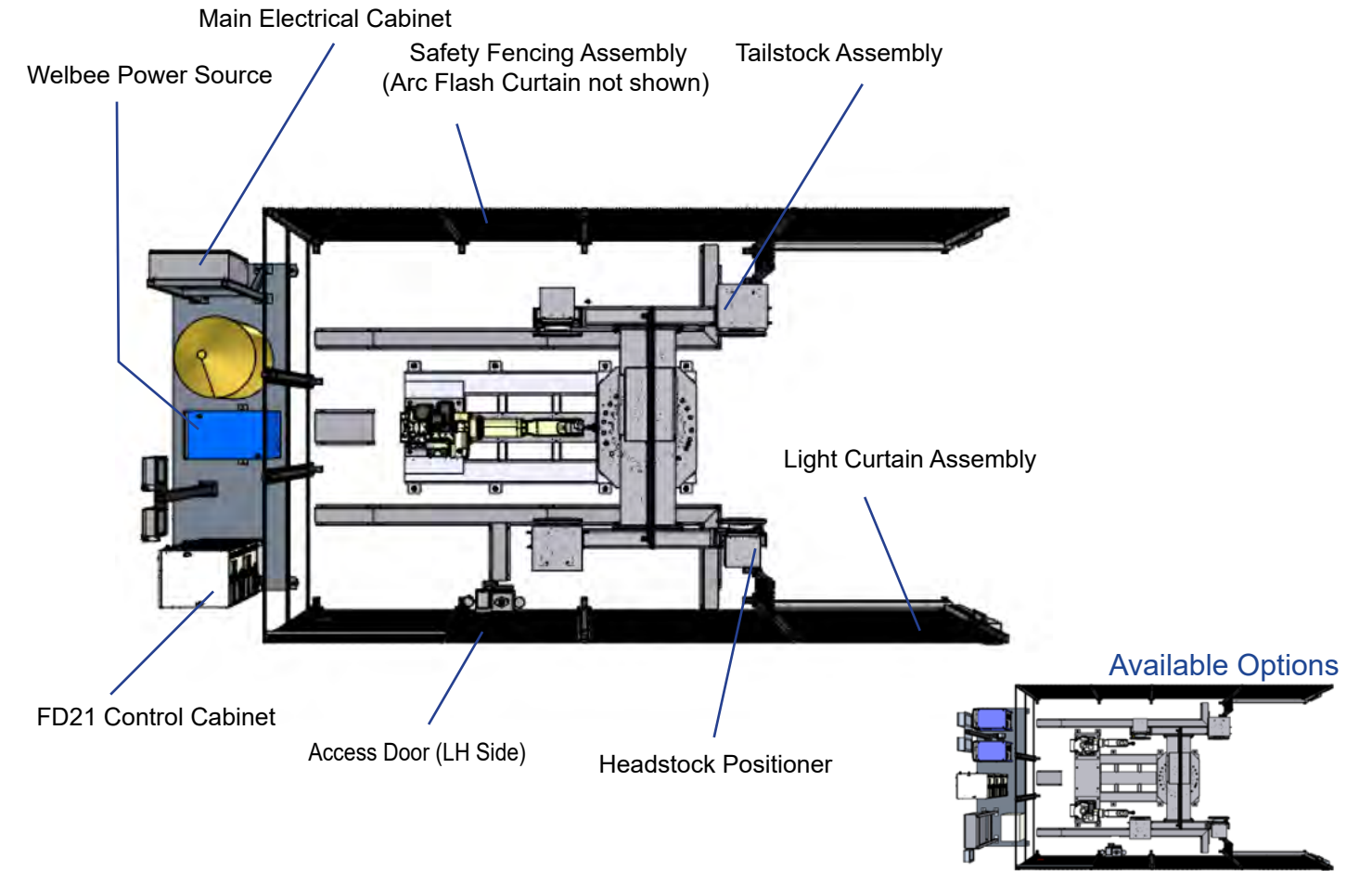
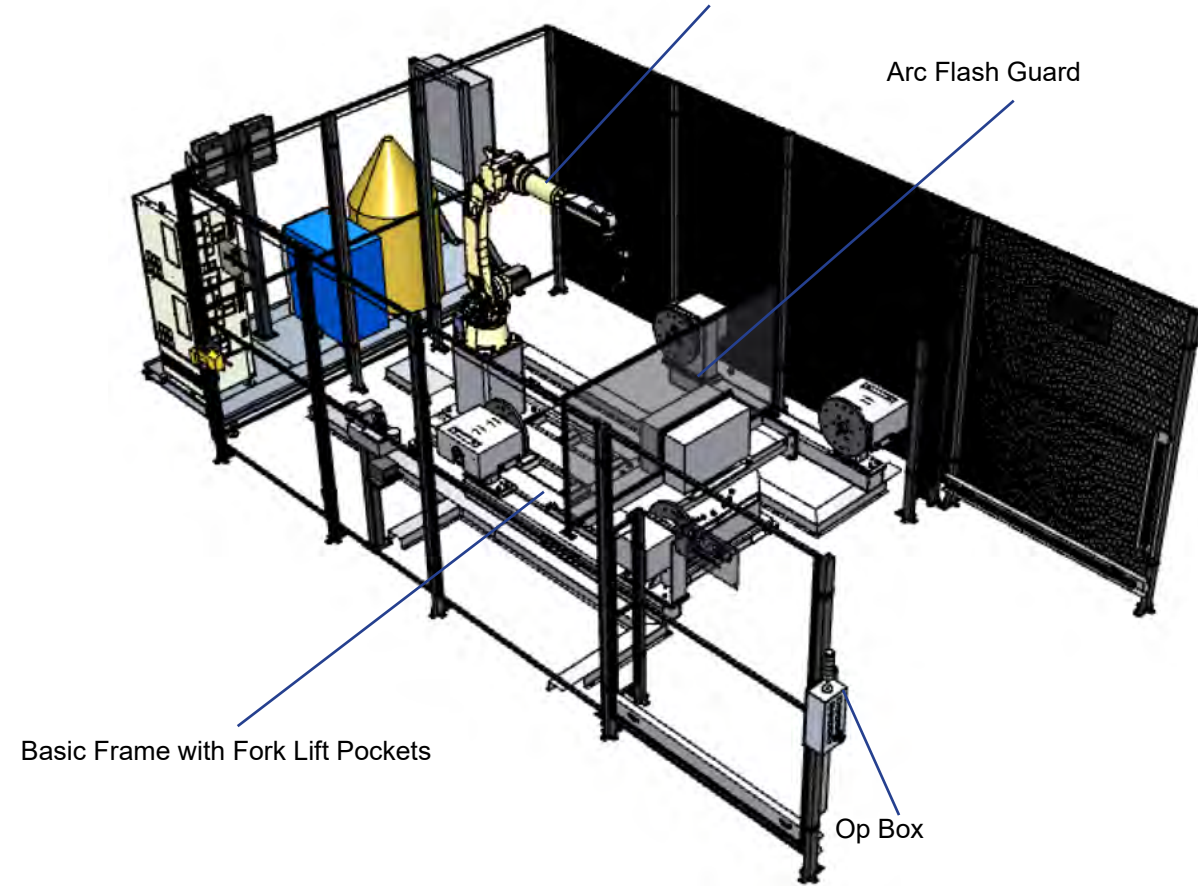

Standard Configuration:

ROTA-ARC 1000

3 Axis Rotary Positioner
with (2) Headstock/Tailstock Stations

Details:

- Work Capacity: 1000kg/side
- Weight: Approx. 4500kg
- Standard fork lift pockets in base
- Standard HS/TS span: 1500mm
- Index Speed: 5 seconds
- HS/TS swing diameter: 1000mm
- Floor mounted safety fencing w/ arc flash curtains
- Utility trailer

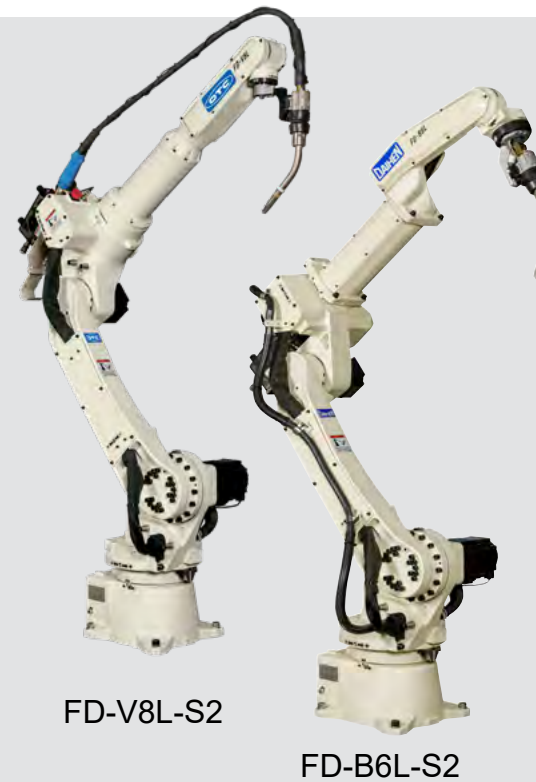

FD-V8L-S2

FD-B6L-S2

Specifications:

Footprint Dimensions:

Width: 3398 mm (133.8")
Height: 2200mm (86.6")
Depth: 6732mm (265.0")

Manipulator Types:

- FD-V8
- FD-V8L-S2
- FD-B6
- FD-B6L-S2

Available I/O Slots:

21 Inputs/29 Outputs
(Additional Power Supply needed for Outputs)

Other Options:

- HS/TS span of 2000mm max.
- Torch cleaning station
- Access door on RH side
- Multiple manipulators
- Extended I/O (recommended)

TRI-ARC 1000

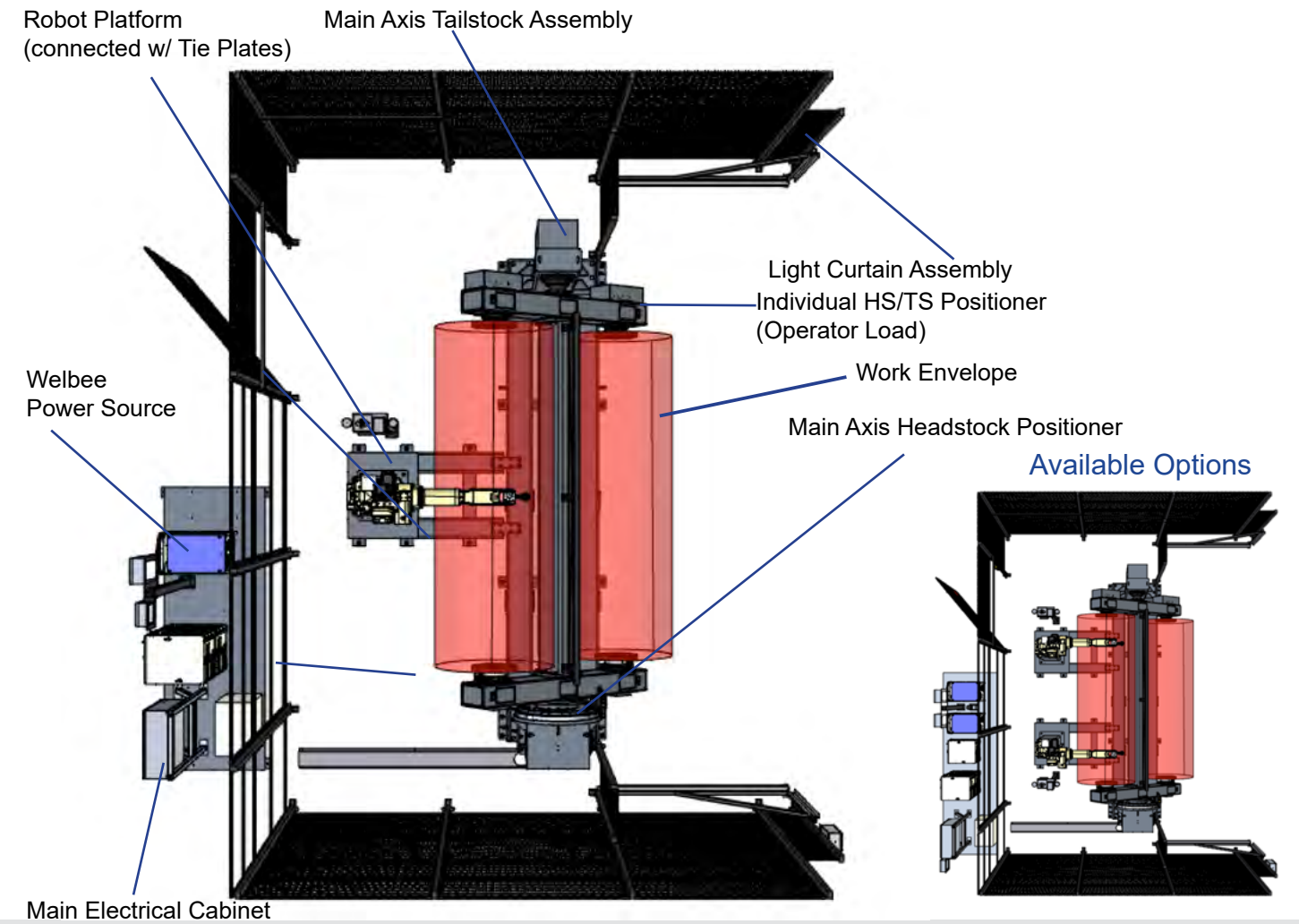
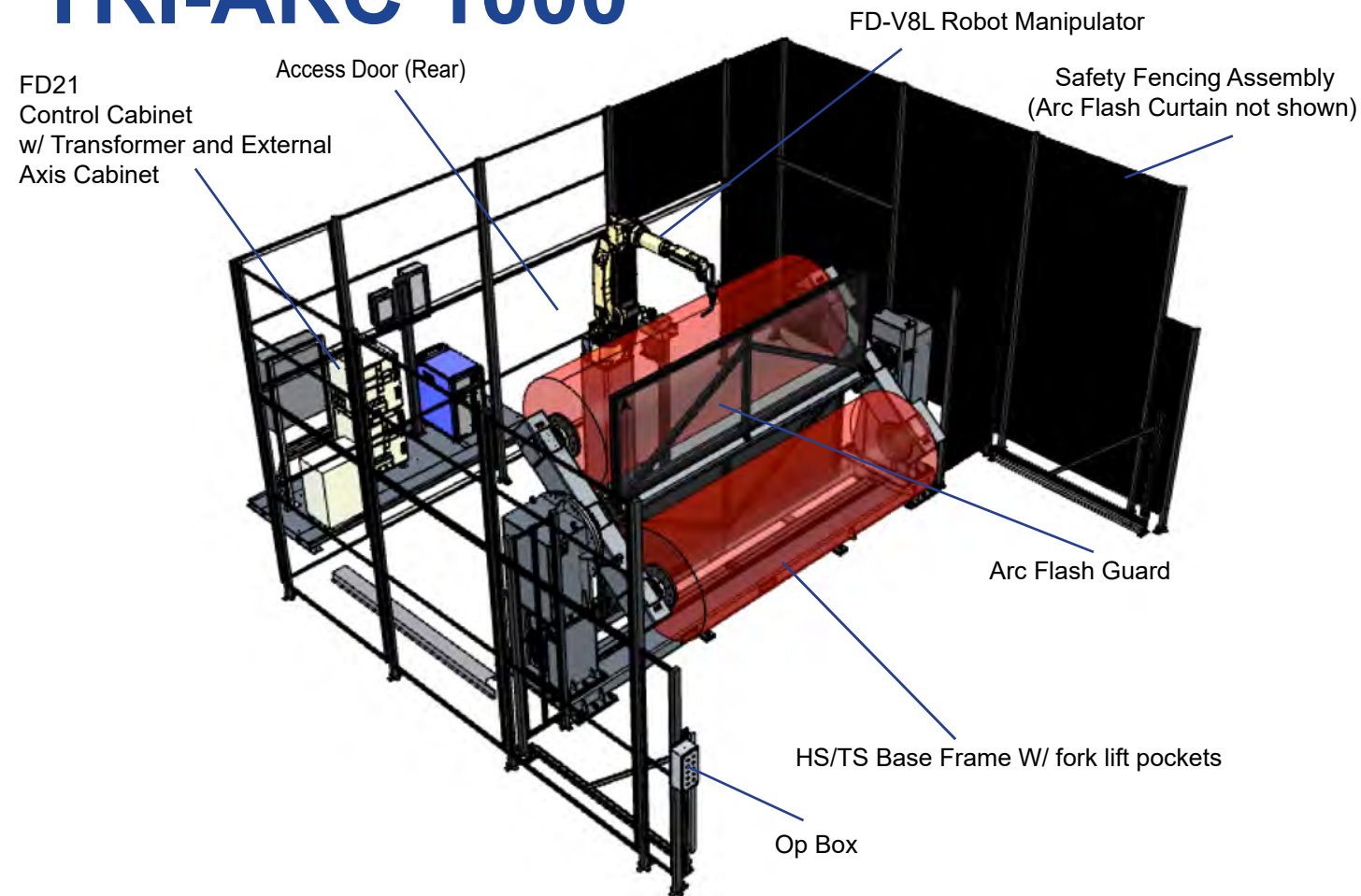

Standard Configuration:

TRI-ARC 1000

3 Axis Ferris Wheel Positioner with (2) Headstock/Tailstock Stations

Details:

- Single Load/Unload point
- Work Capacity: 1000kg/side
- Weight: Approx. 5500kg
- Standard fork lift pockets in base
- Standard HS/TS span: 2000mm
- Index Speed: 5 seconds
- HS/TS swing diameter: 1050mm
- Robot platform connected with tie plates
- Floor mounted safety fencing w/ arc flash curtains
- Utility Trailer



Specifications:

Footprint Dimensions:

Width: 5618mm (221.2")
 Height: 3460mm (136.2")
 Depth: 6437mm (253.4")

Manipulator Types:

- FD-V8L-S2
- FD-B6L-S2

Available I/O Slots:

21 inputs / 29 outputs
 (Additional Power Supply needed for Outputs)

Other Options:

- HS/TS span of 4000mm max.
- Torch cleaning station
- Access door on RH or LH side
- Multiple manipulators w/ platform
- Extended I/O (recommended)

888-OTC-ROBO



DAIHEN Inc.

www.DAIHEN-USA.com

OTC DAIHEN Inc considers the contents of this robotic price catalog as proprietary and confidential information. Therefore, it shall be considered unwarranted to solicit or otherwise disclose the information to any unauthorized third-party. All pricing information and specifications are subject to change without notice. Please contact your regional sales manager or our main headquarters to request a current version of this catalog.

North American Corporation Headquarters

1400 Blauser Dr, Tipp City, Ohio 45371 / Phone: (937) 667-0800

Technical Centers

Detroit, MI Branch
Atlanta, GA Branch